

# IT & THEY

## PRACTICE

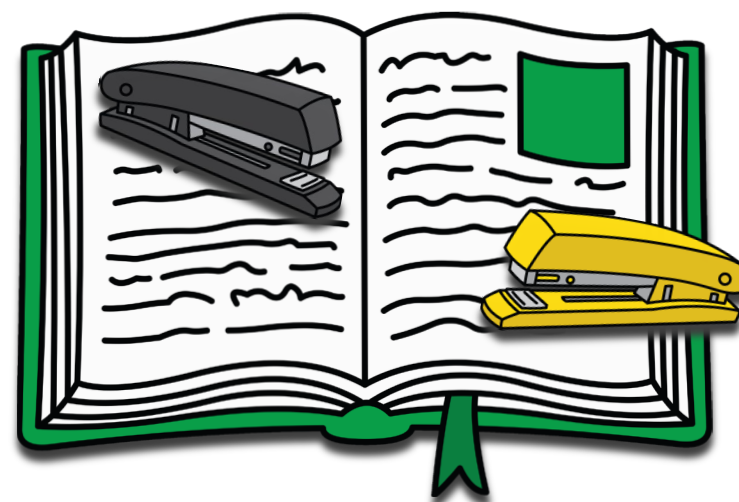

IT &  
THEY

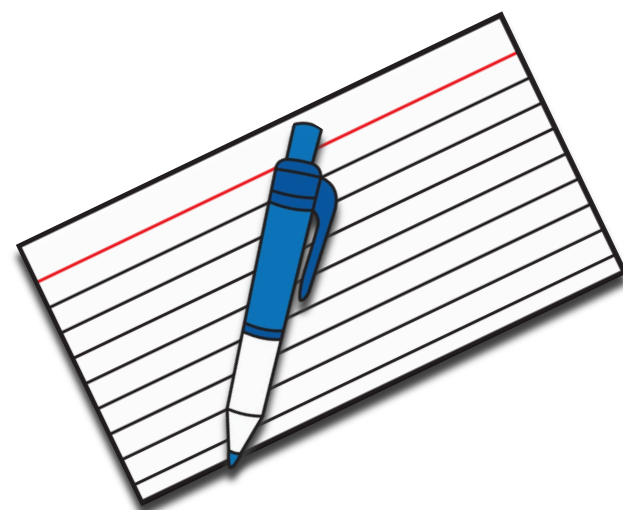
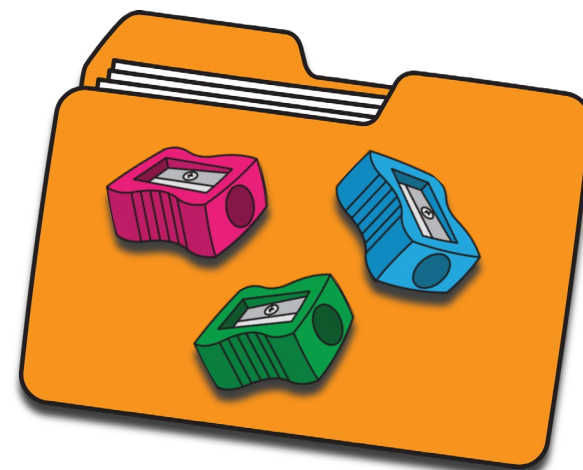
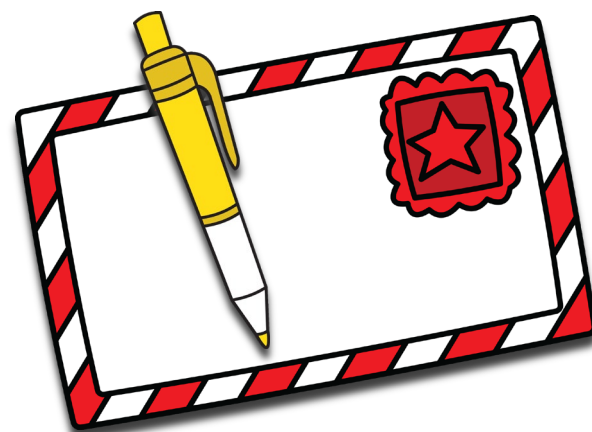



# GROUP 1

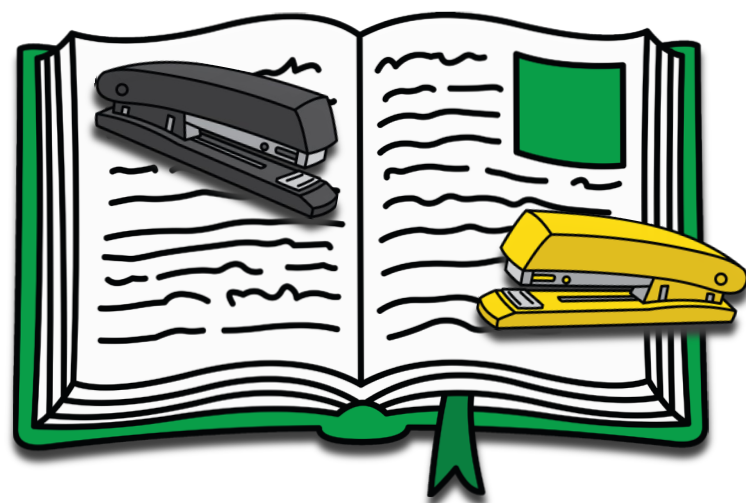
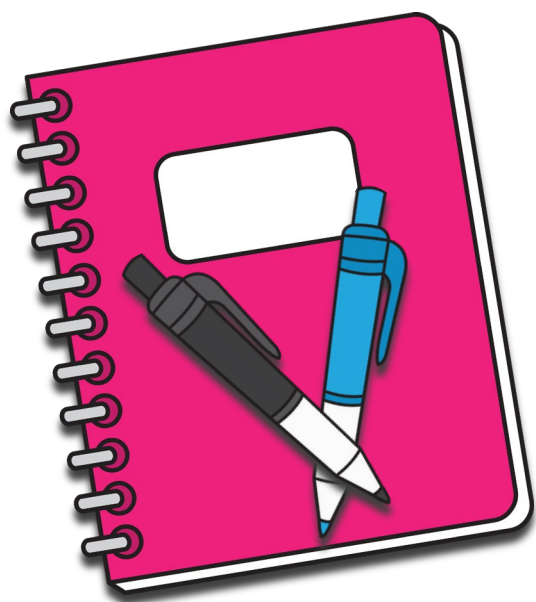
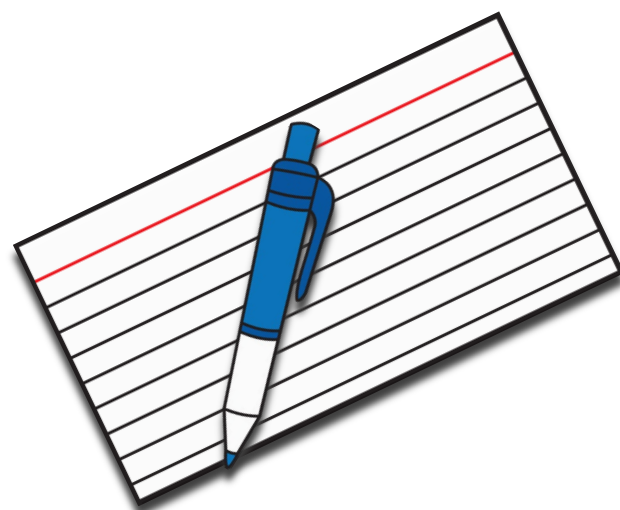
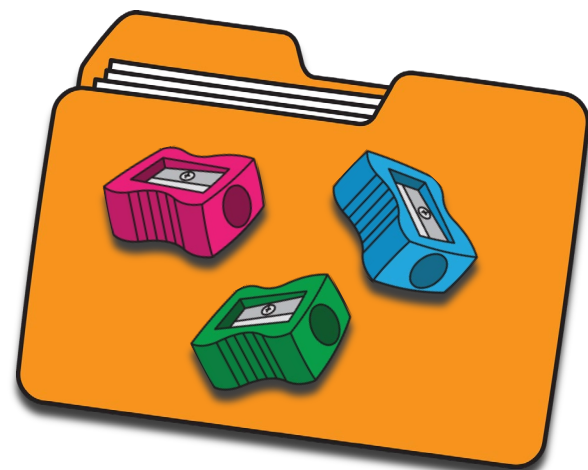
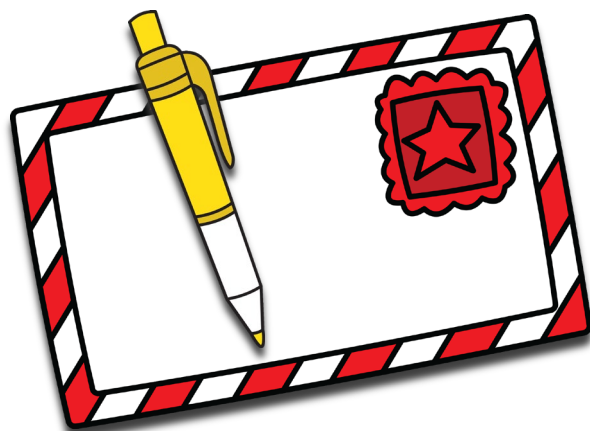

IT &  
THEY





LESSON  
20



Inglés Paso a Paso con Lucie

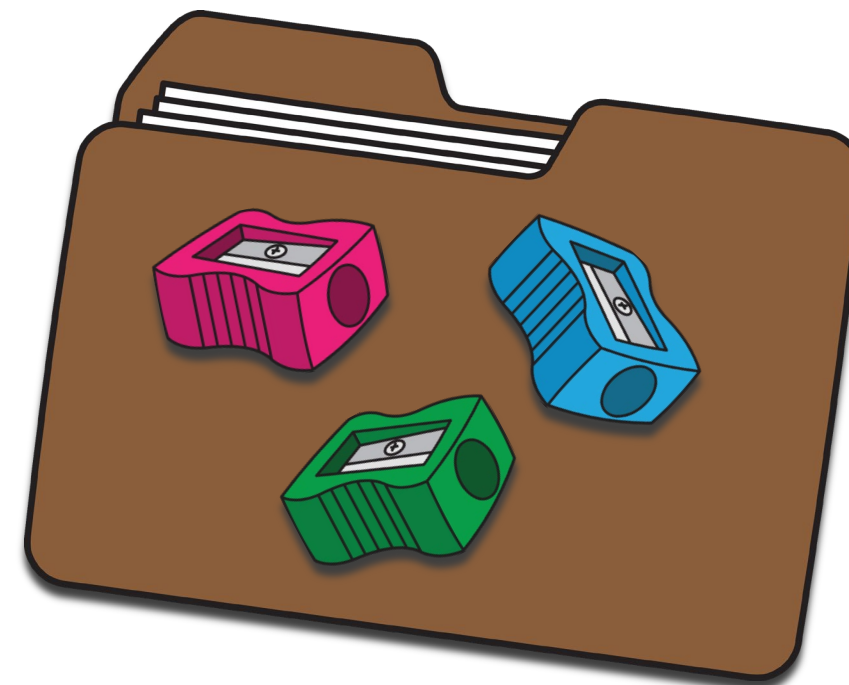
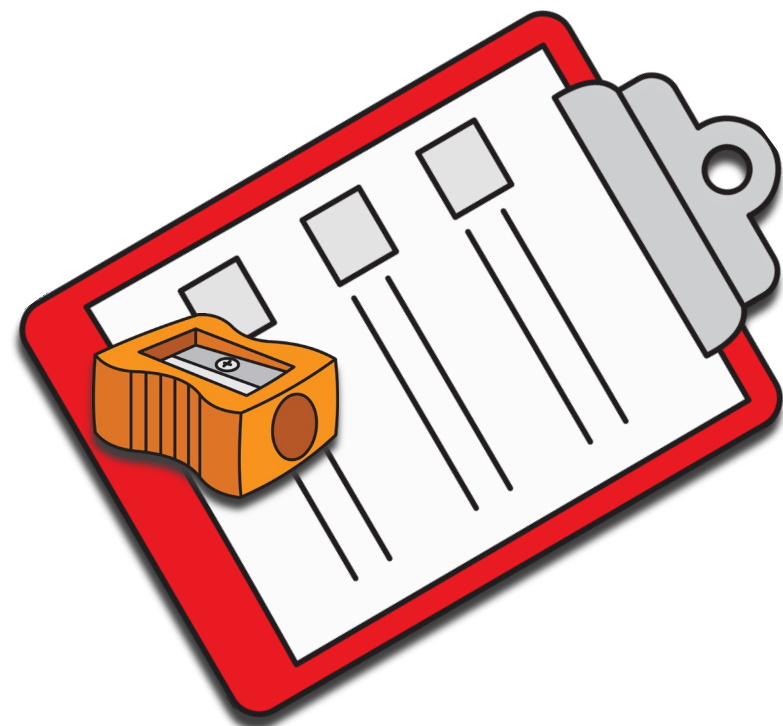

IT &  
THEY

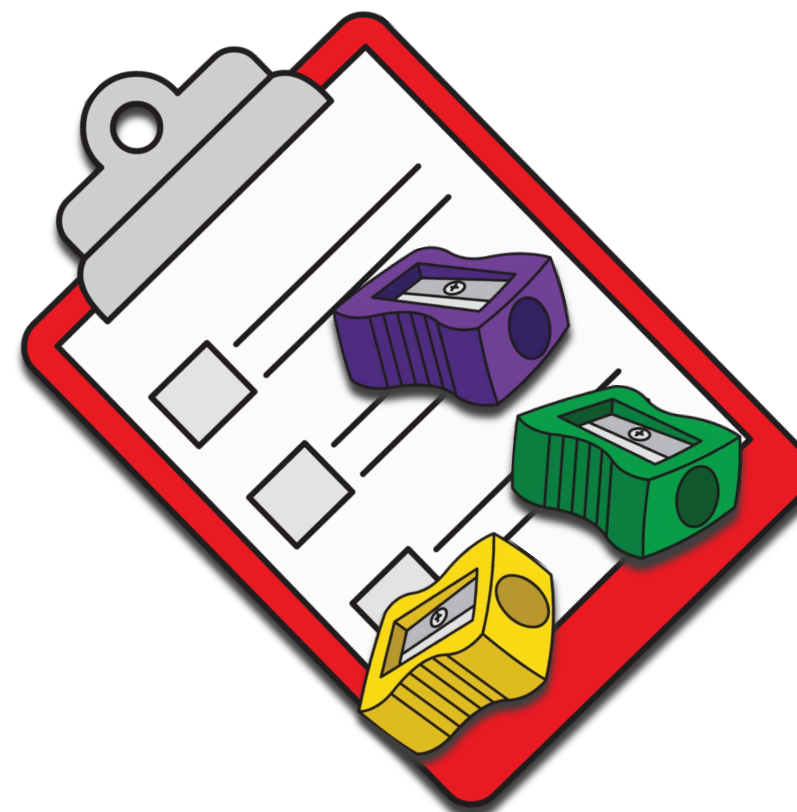





**THE SHARPENER IS  
ON THE NOTEBOOK.**

IT &  
THEY







**IT IS**

**ON THE NOTEBOOK.**

**IT &  
THEY**







**IT'S**

**ON THE NOTEBOOK.**

**IT &  
THEY**





LESSON  
20



Inglés Paso a Paso con Lucie

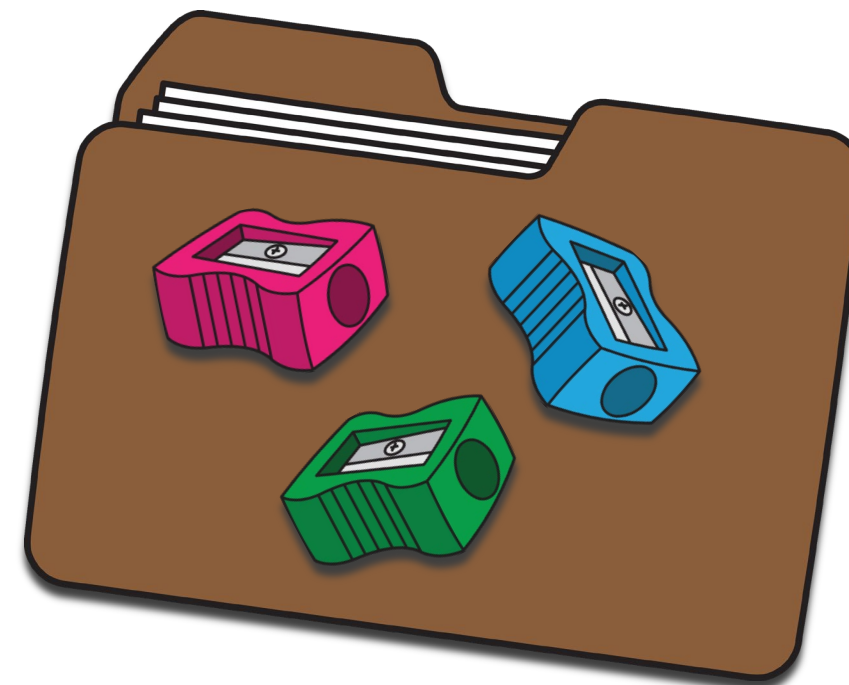
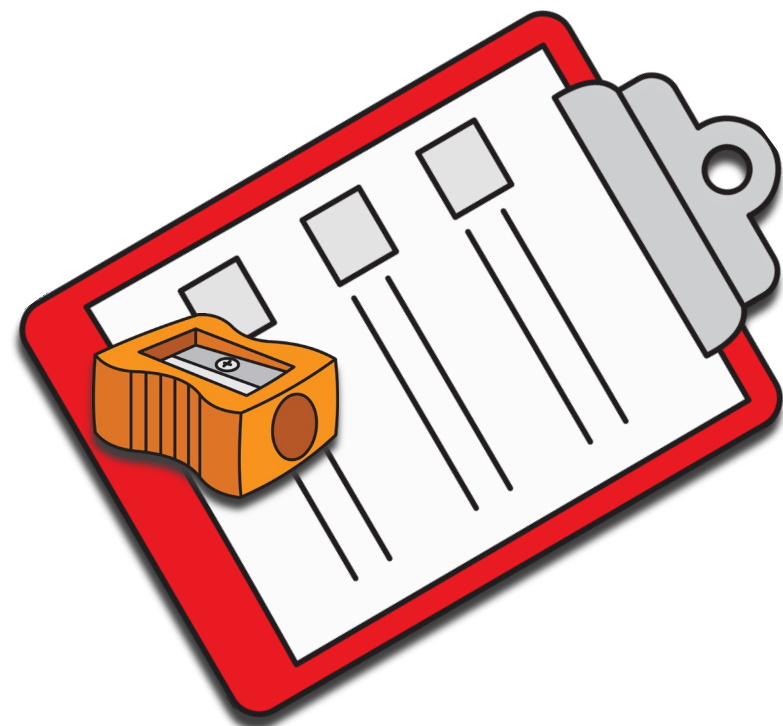

IT &  
THEY

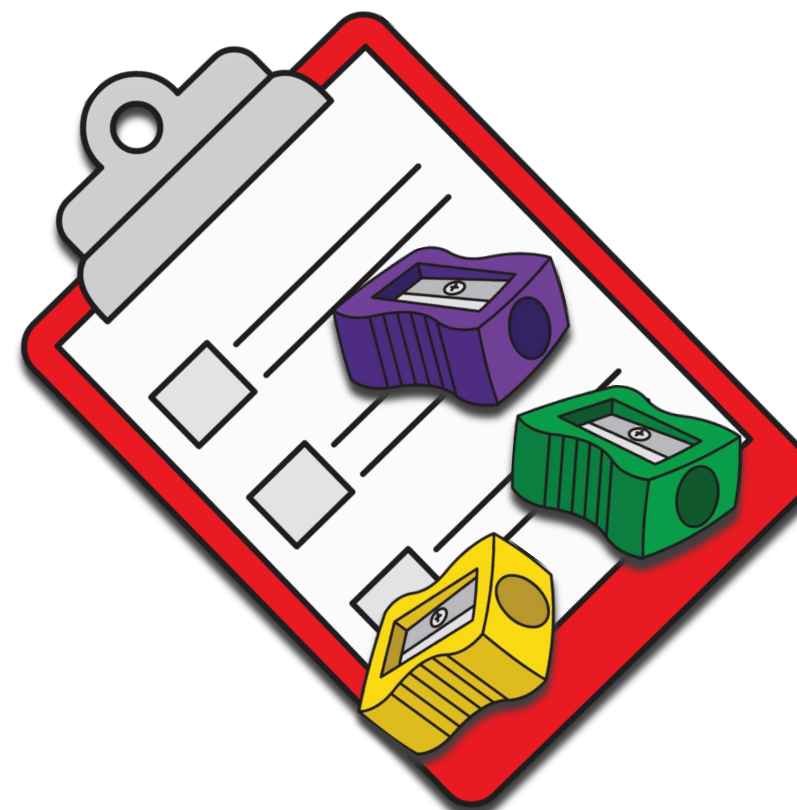



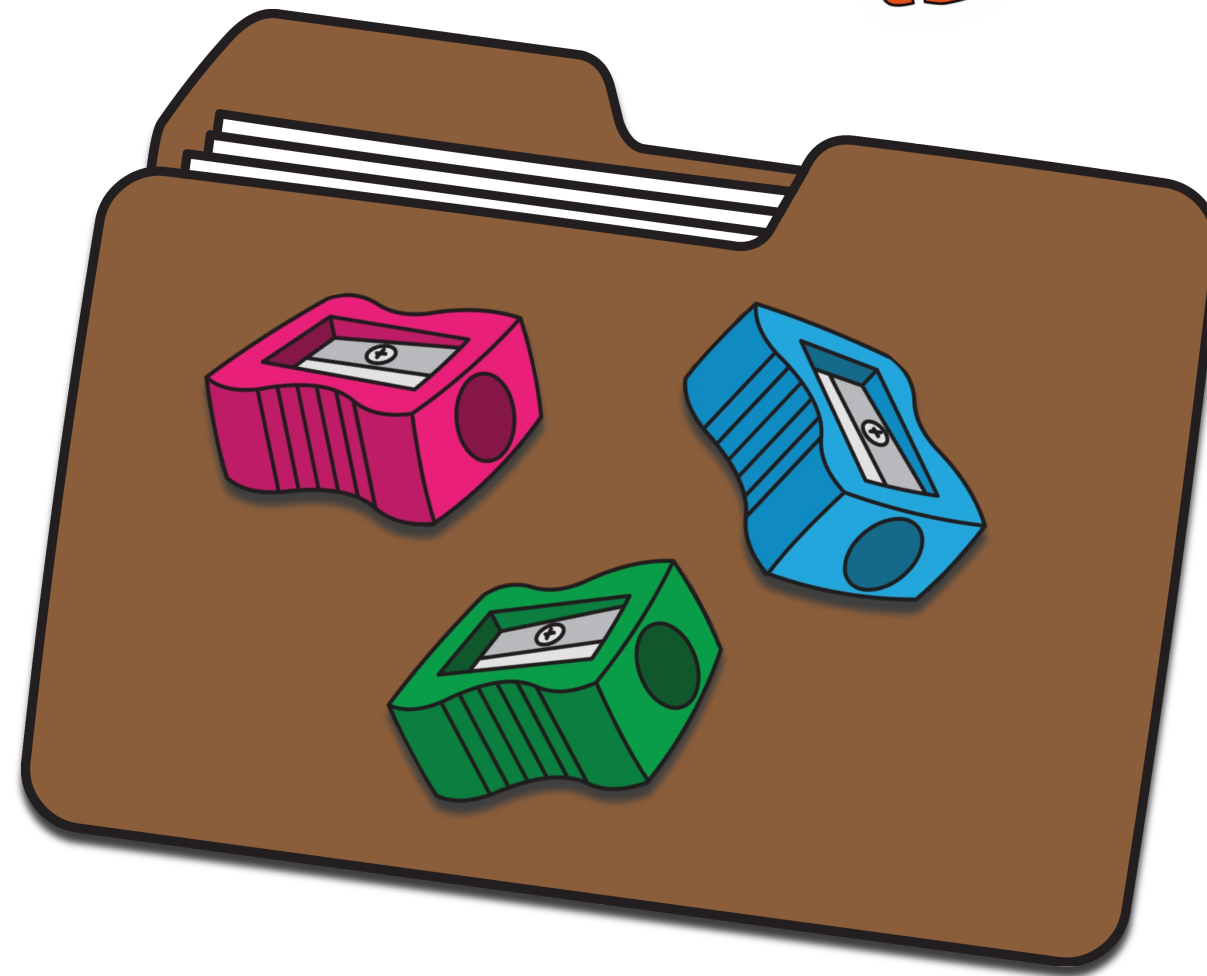

IT &  
THEY

**THE SHARPENERS ARE  
ON THE FILE FOLDER.**





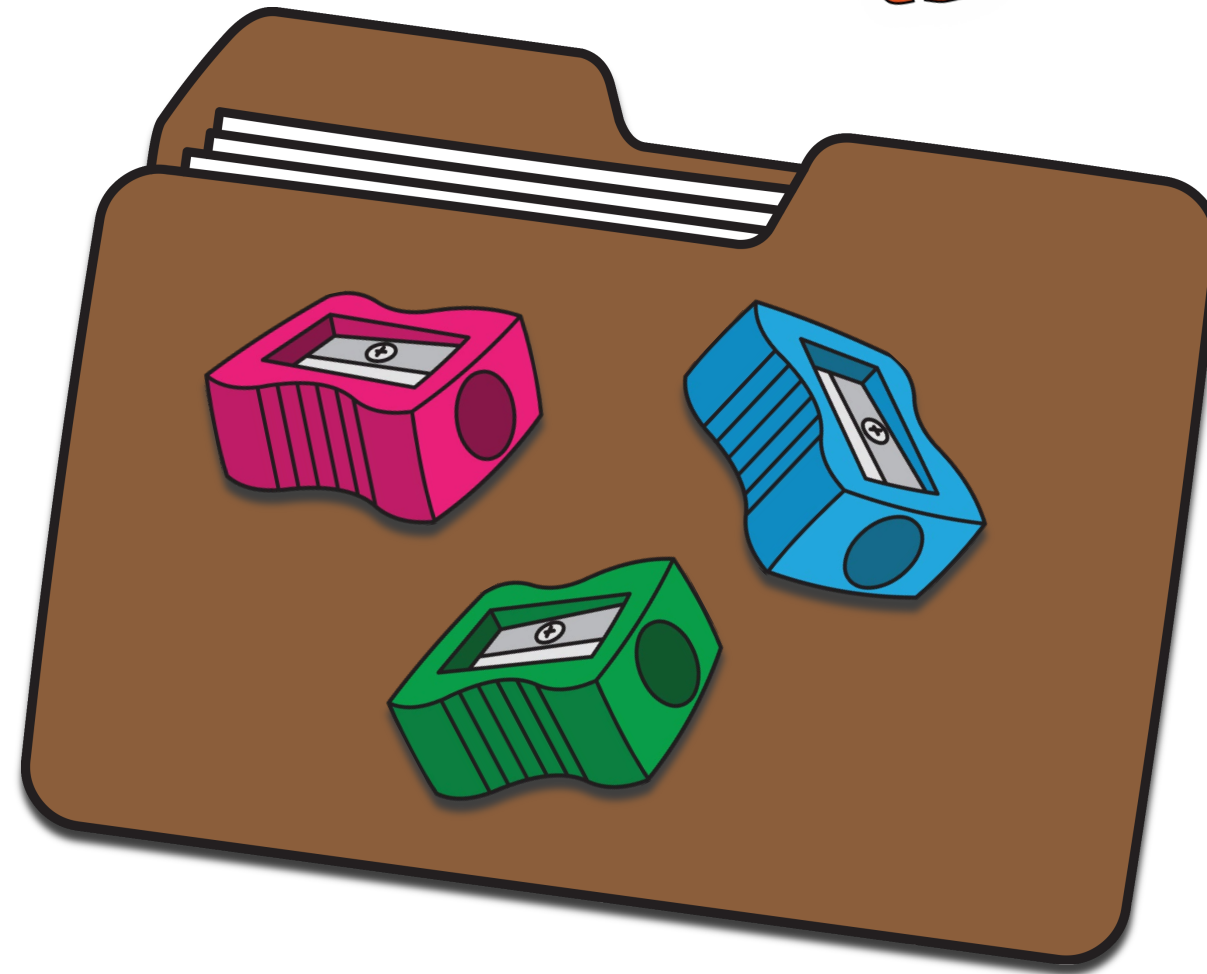

IT &  
THEY

**THEY ARE  
ON THE FILE FOLDER.**





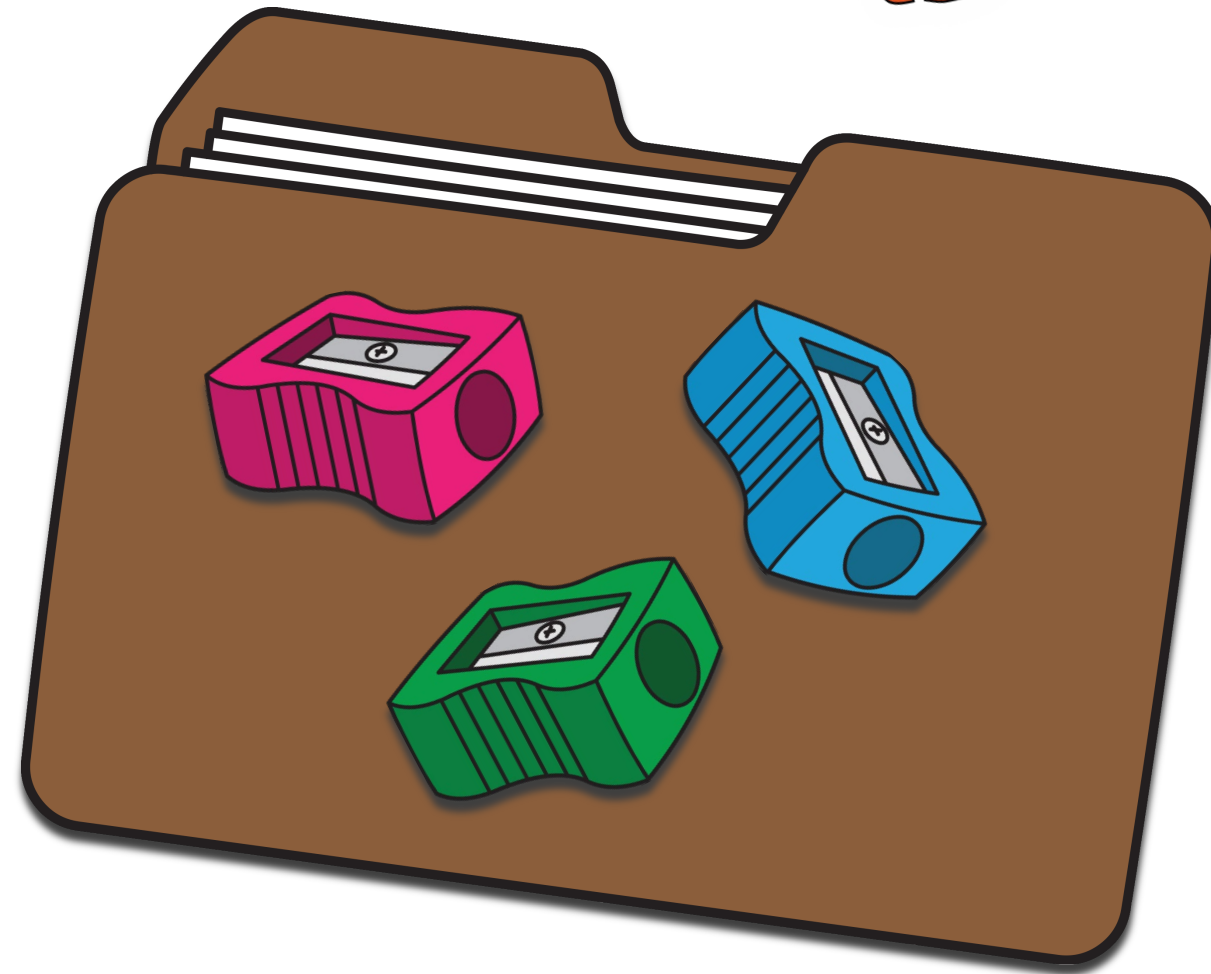

IT &  
THEY

**THEY'RE**  
**ON THE FILE FOLDER.**





LESSON  
20



Inglés Paso a Paso con Lucie

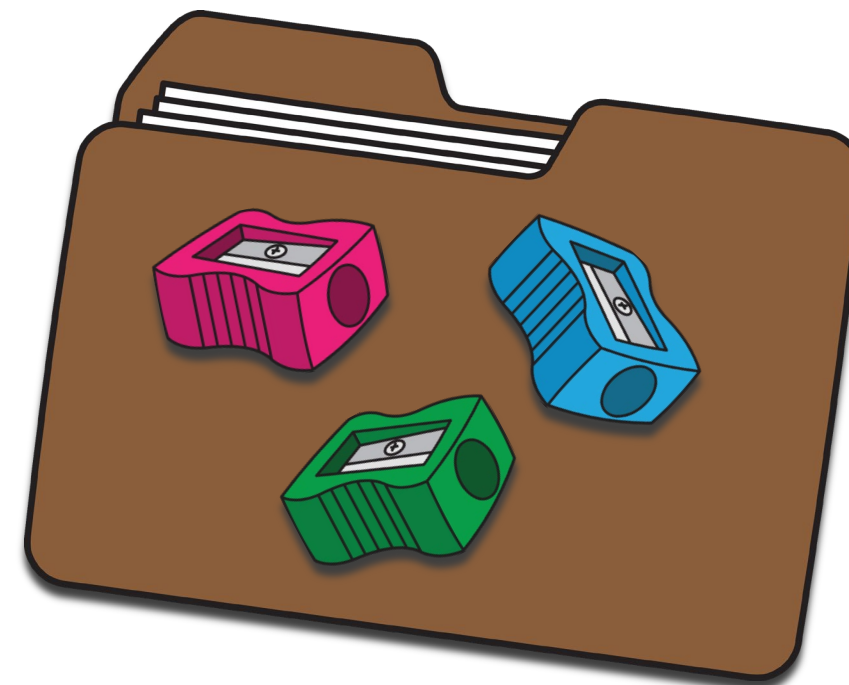
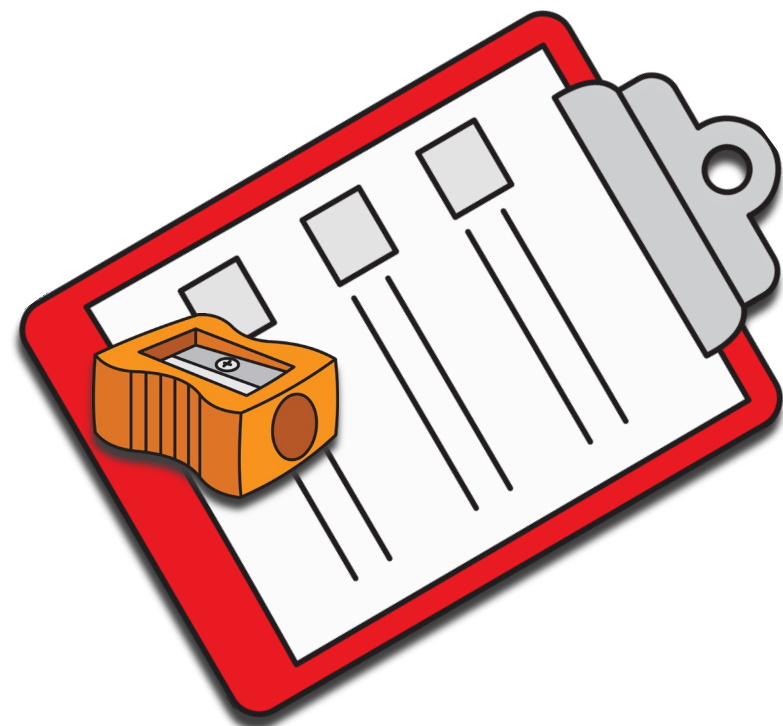

IT &  
THEY

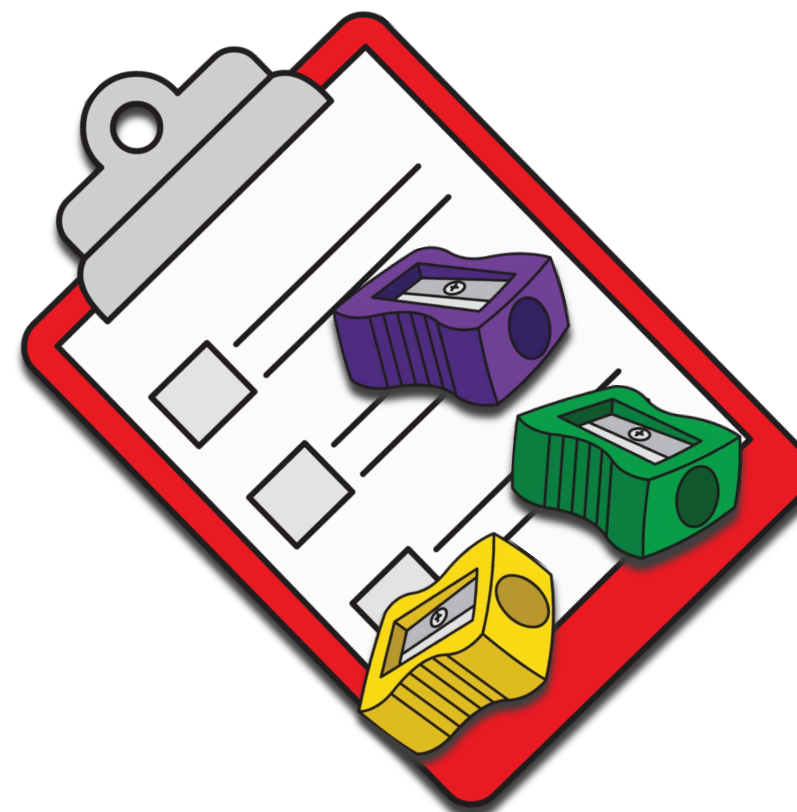



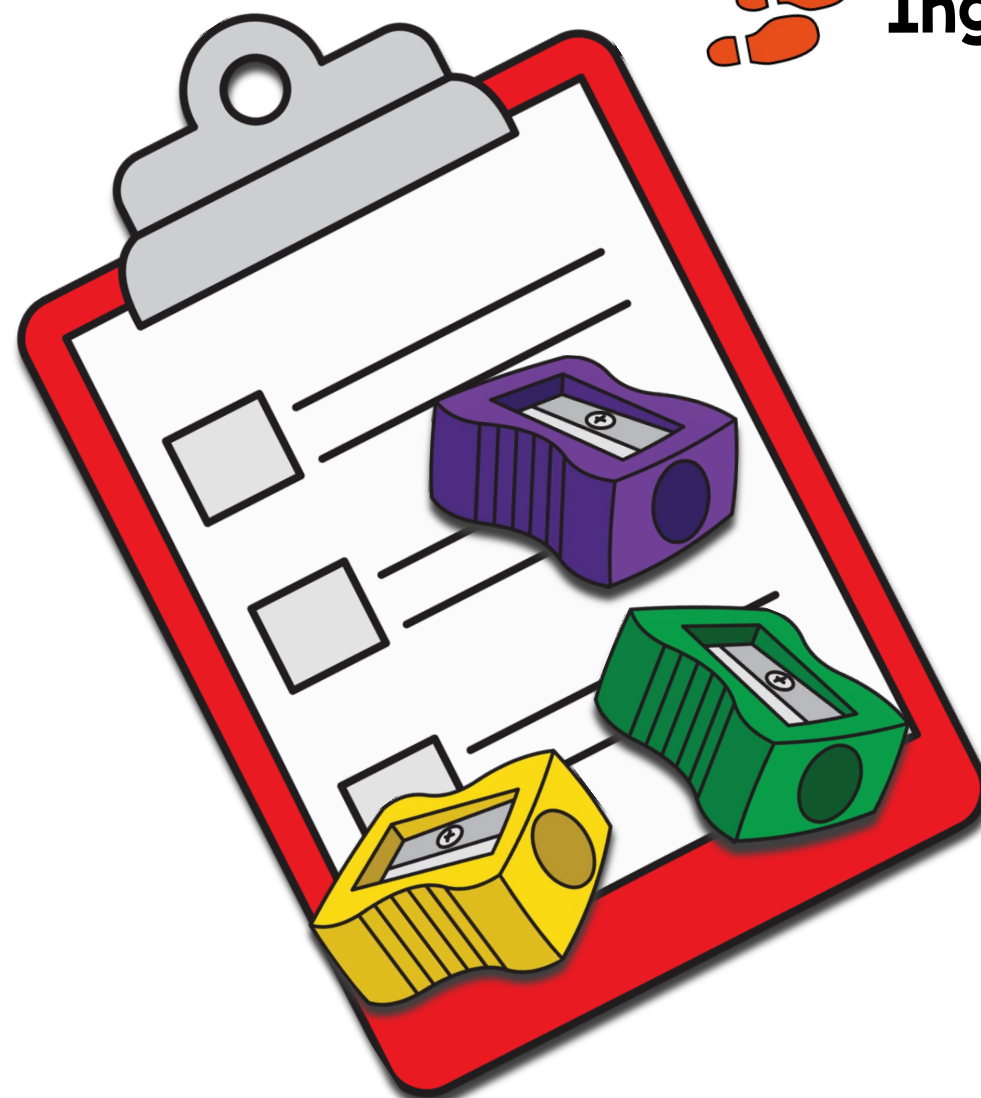

IT &  
THEY

**THE SHARPENERS ARE  
ON THE CLIPBOARD.**





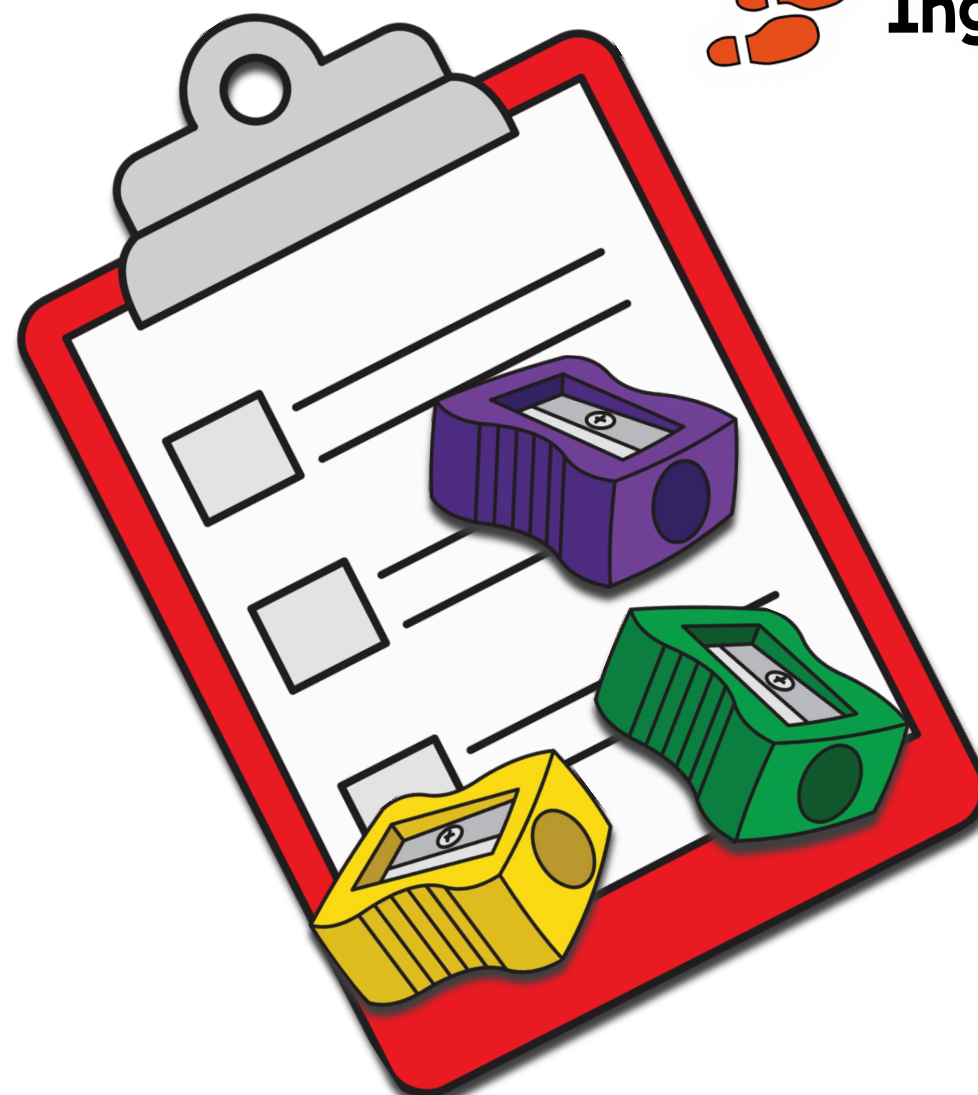

IT &  
THEY

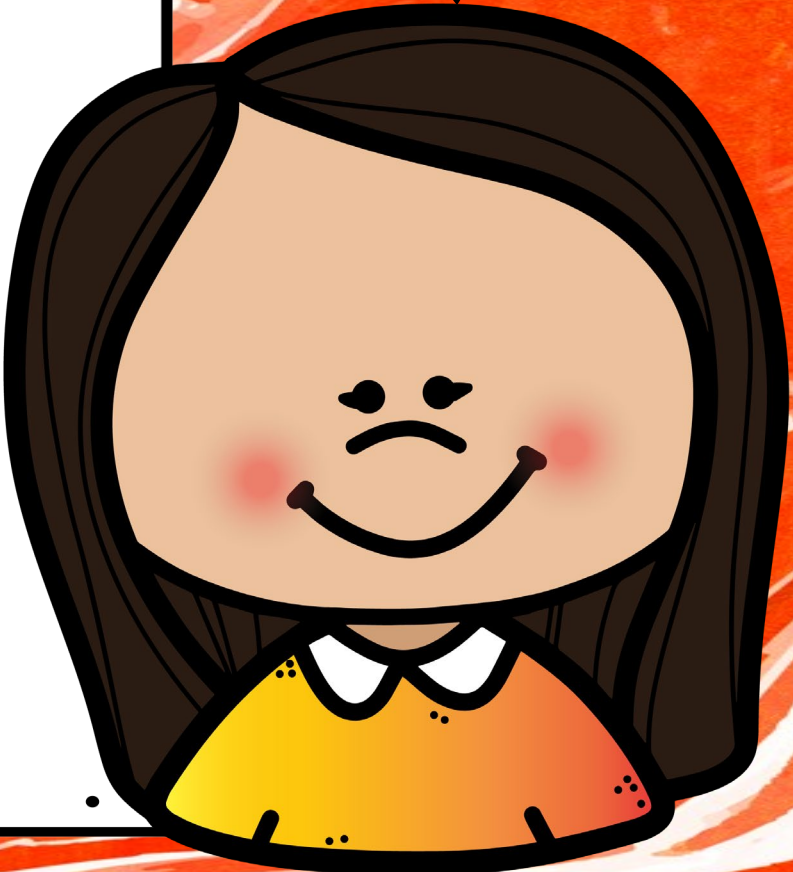

**THEY ARE  
ON THE CLIPBOARD.**



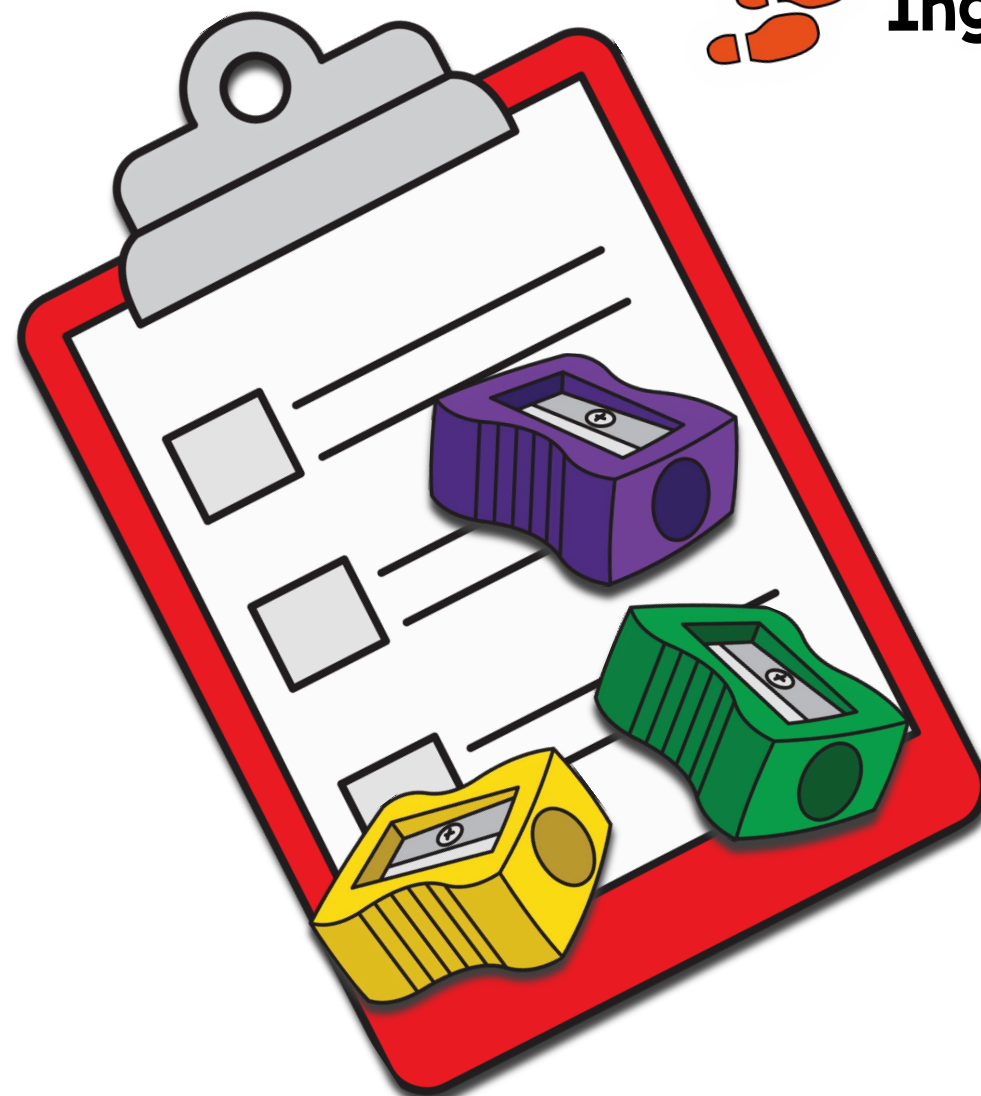

IT &  
THEY

**THEY'RE**  
**ON THE CLIPBOARD.**





# GROUP 2

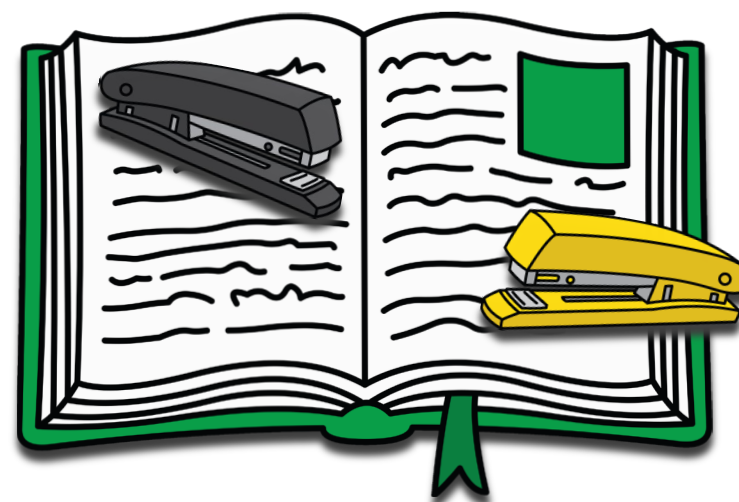
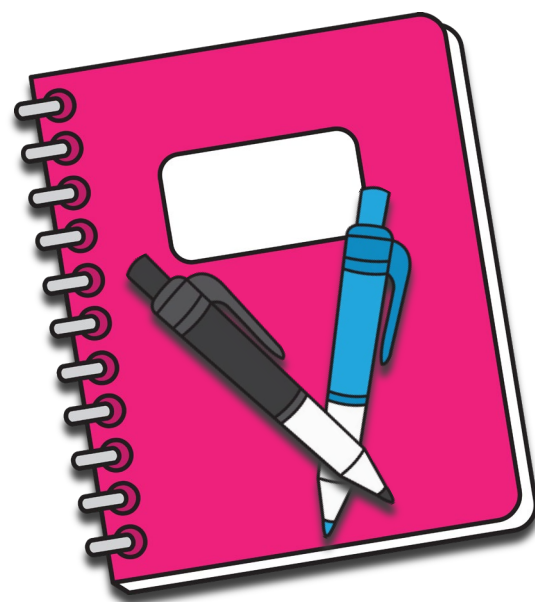
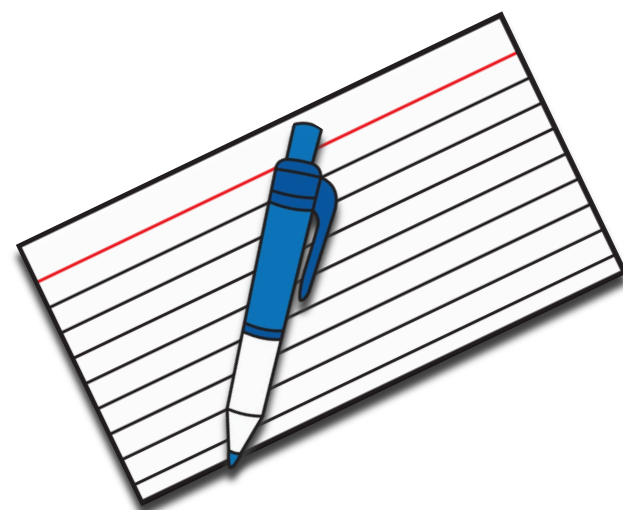
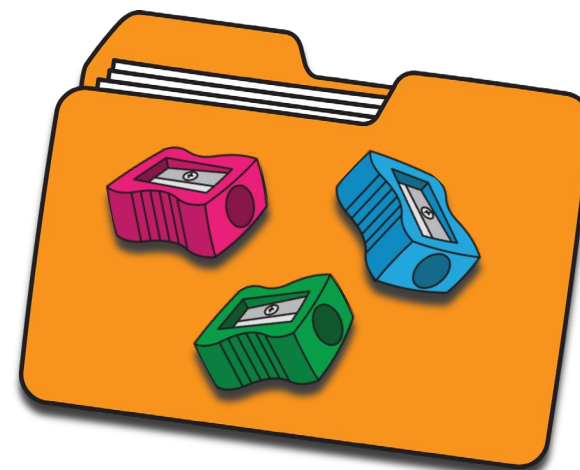
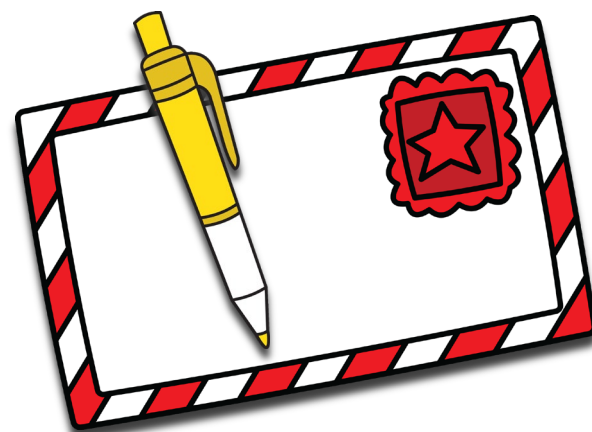

IT &  
THEY





LESSON  
20



Inglés Paso a Paso con Lucie

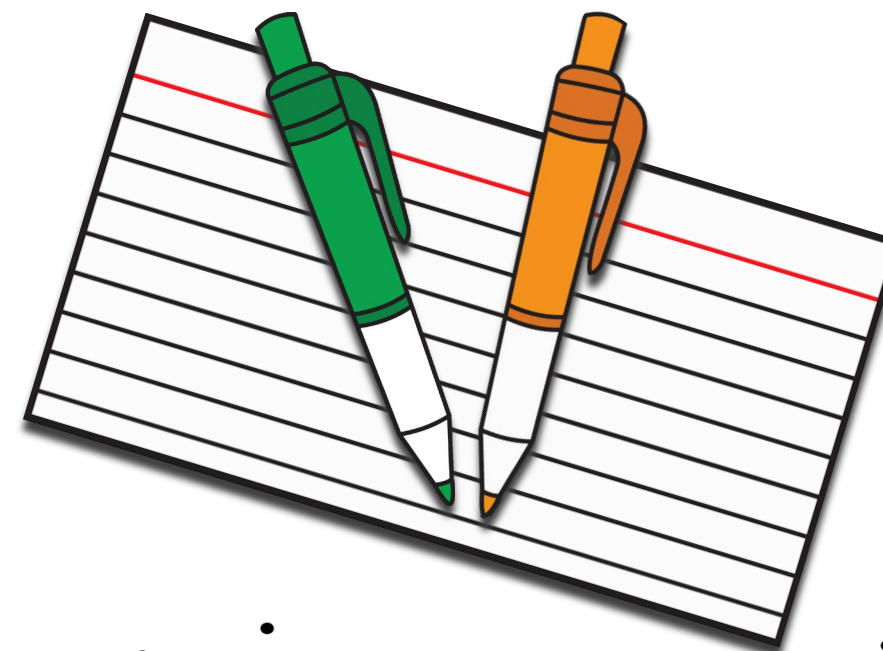
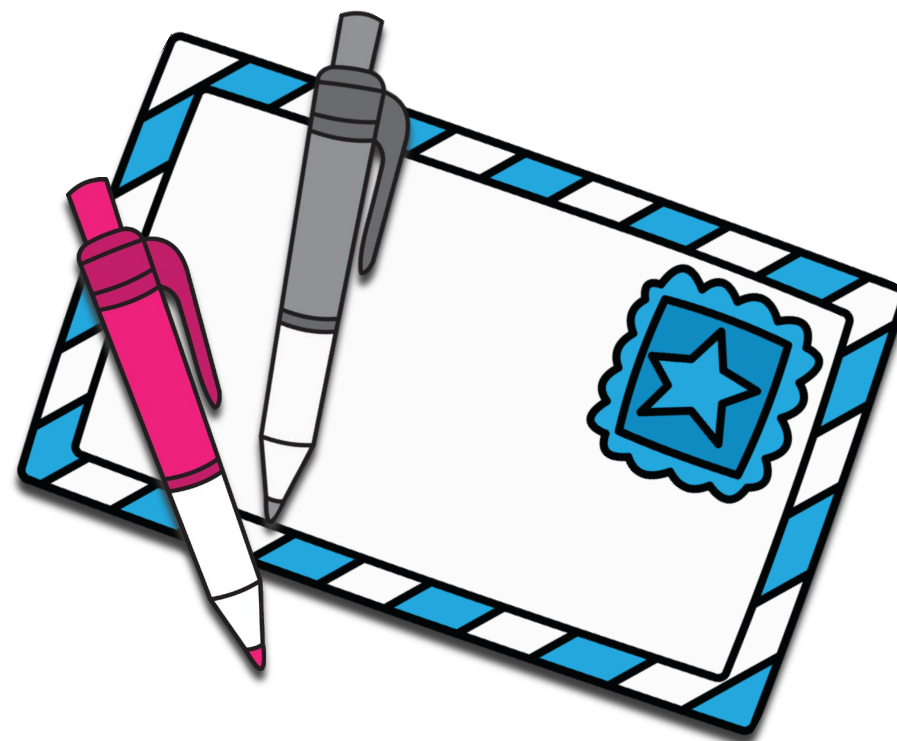
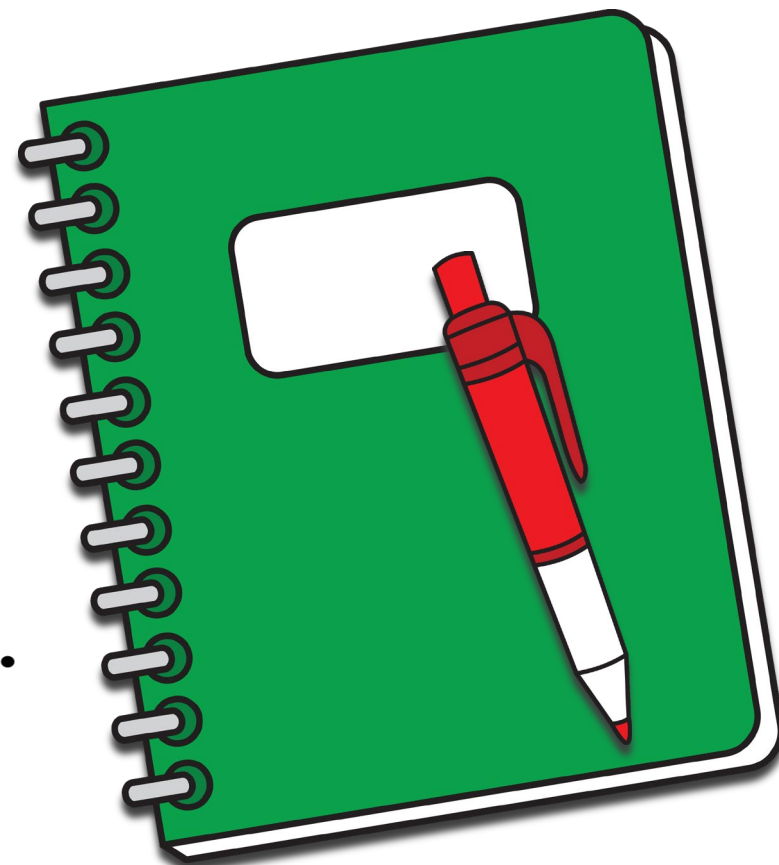
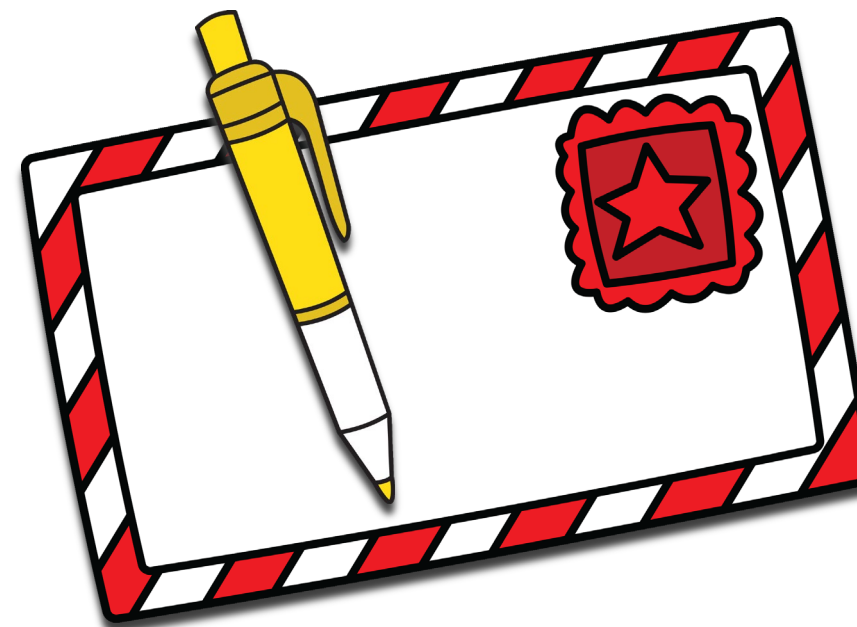
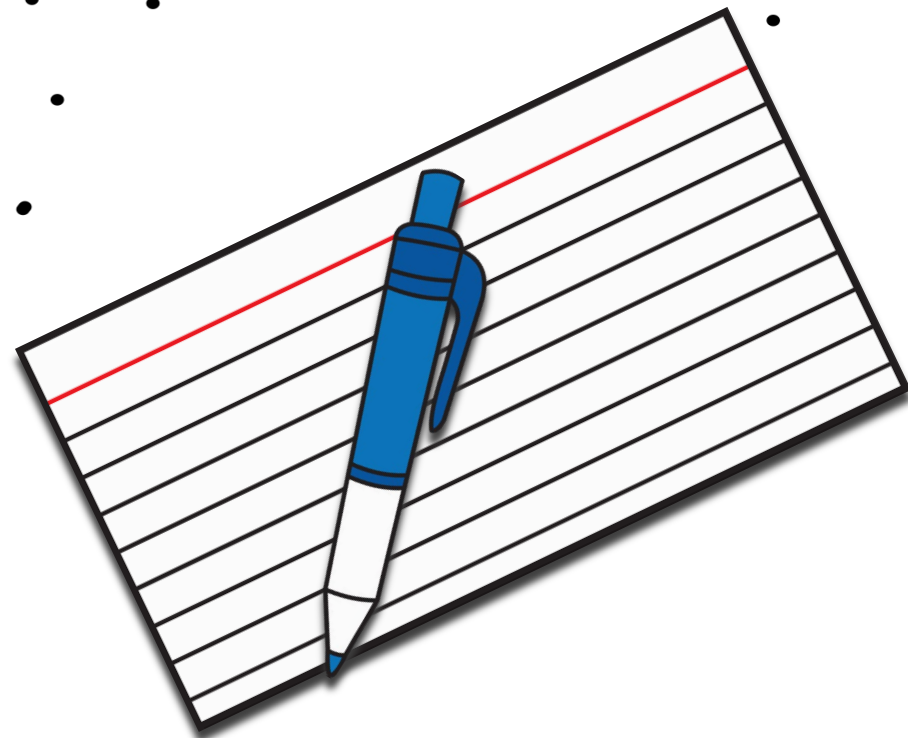

IT &  
THEY





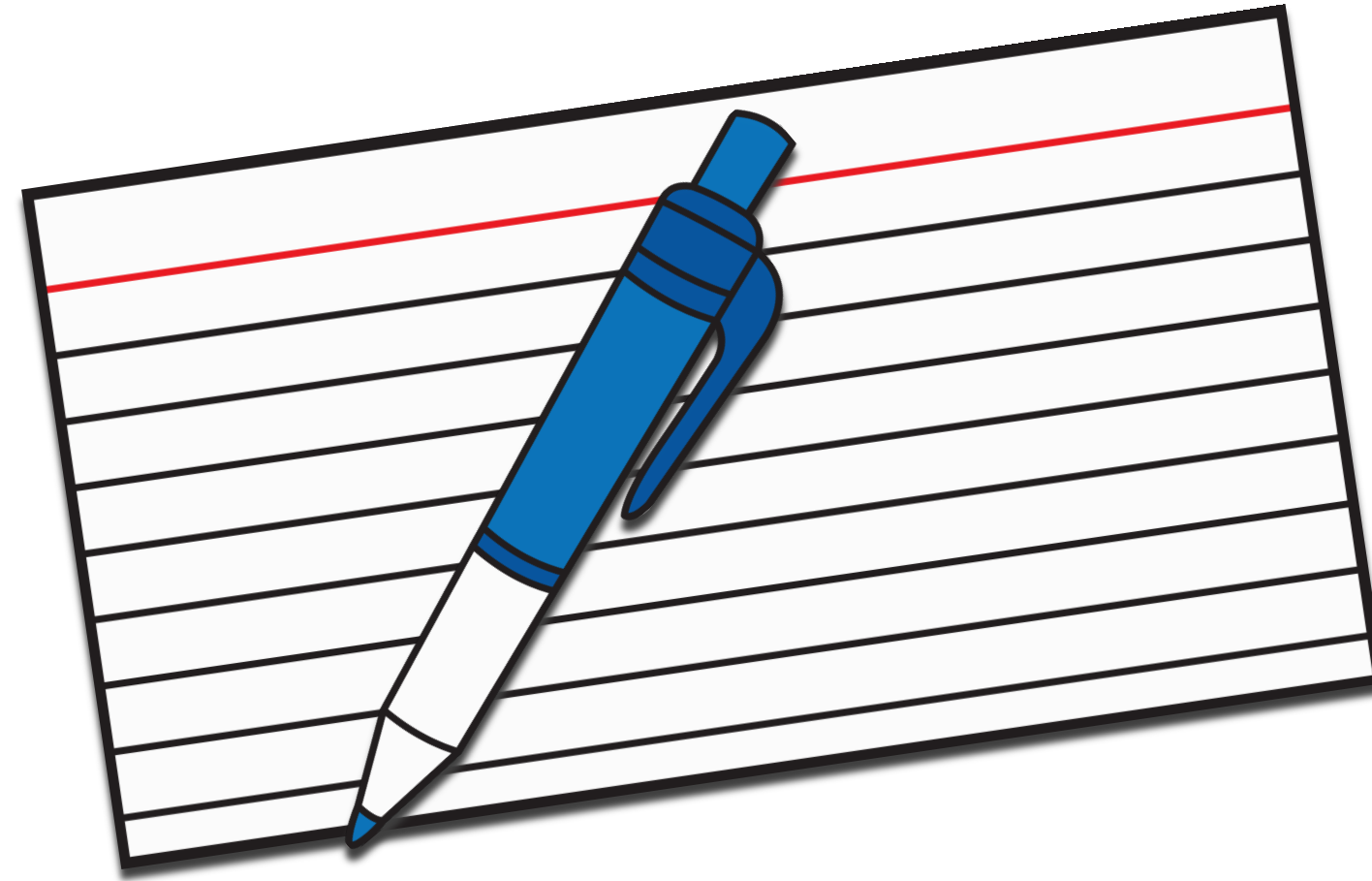

IT &  
THEY

**THE PEN IS  
ON THE INDEX CARD.**





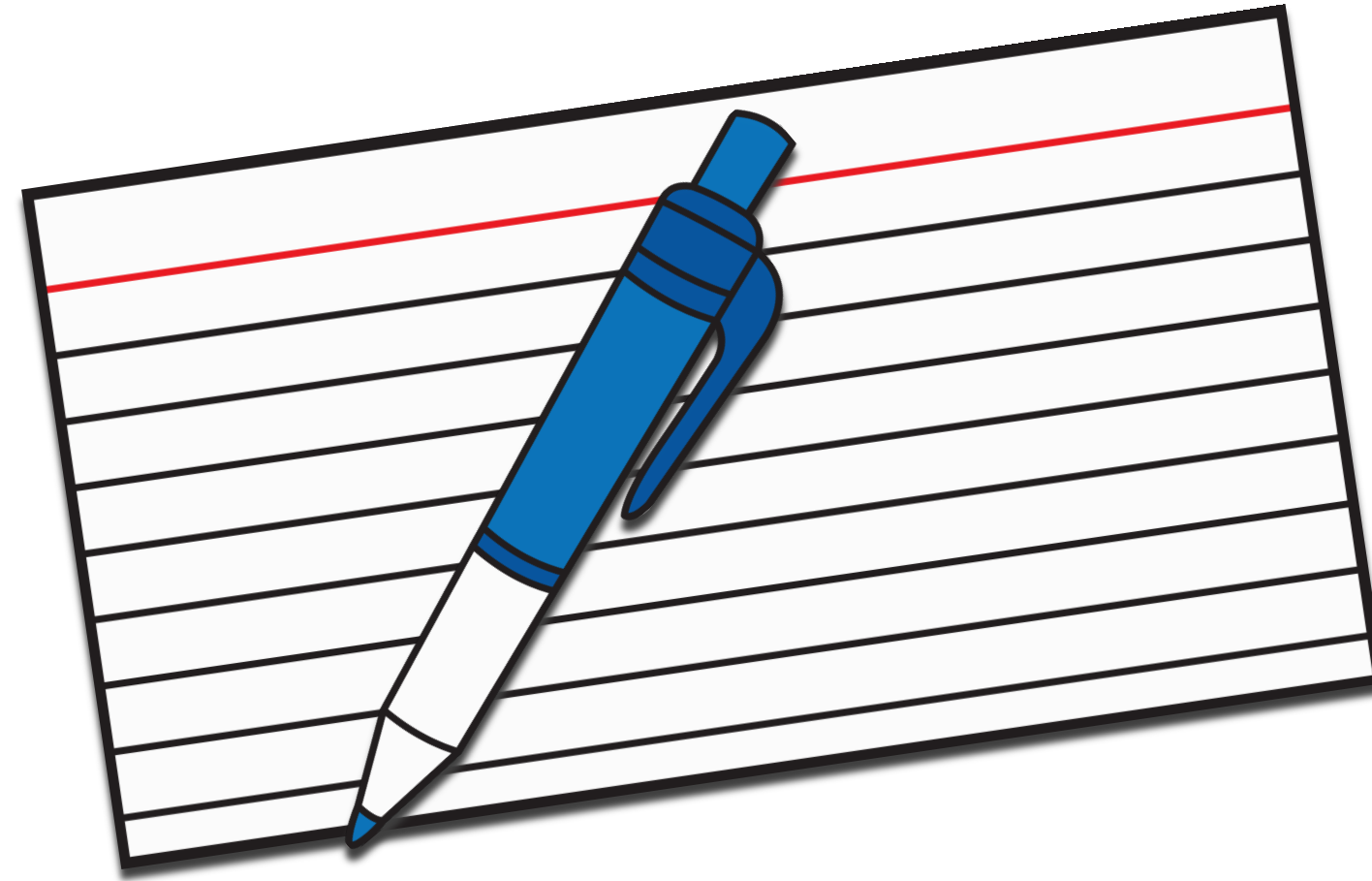

IT &  
THEY

**IT IS**  
**ON THE INDEX CARD.**





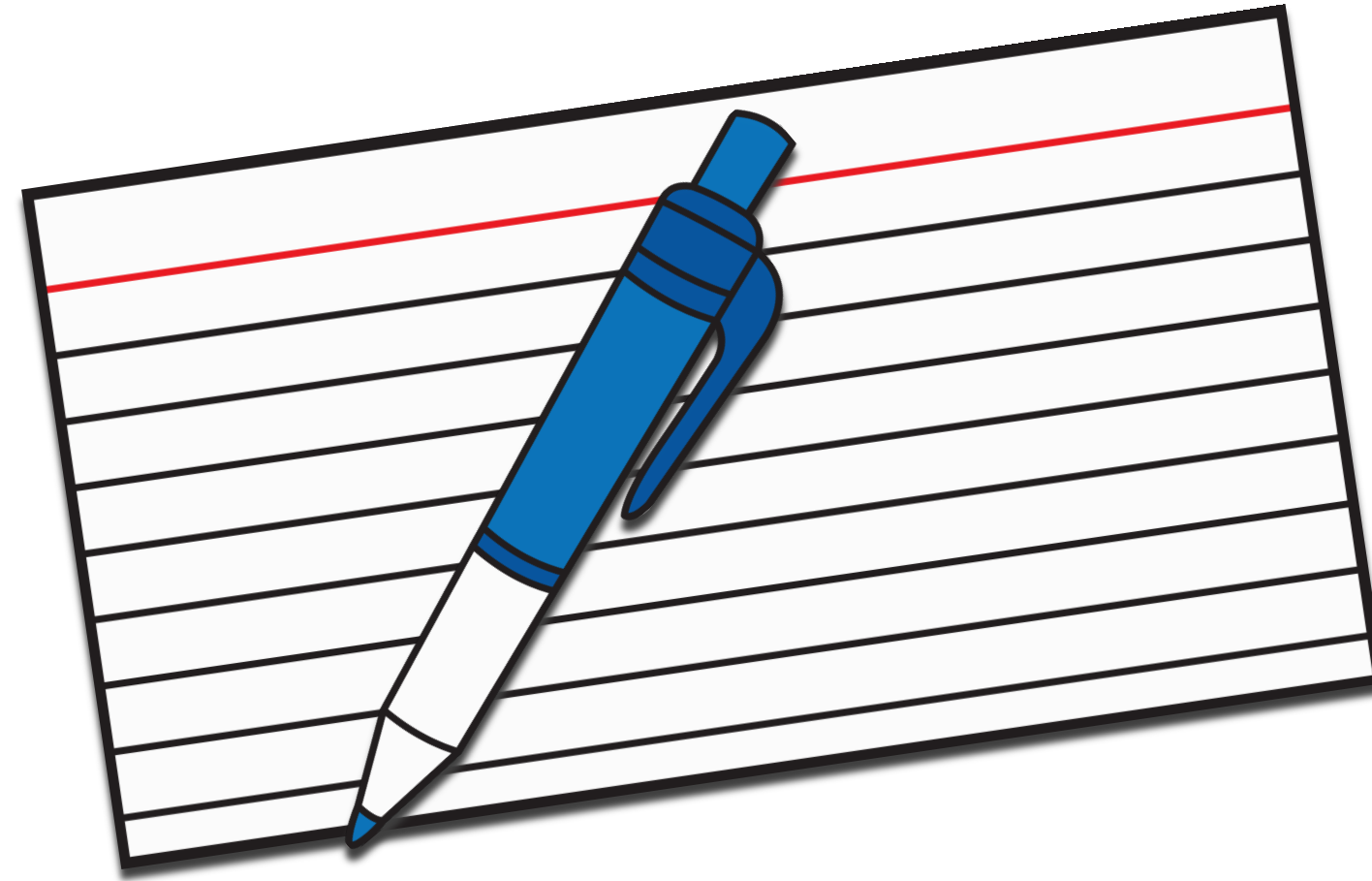

IT &  
THEY

**IT'S**  
**ON THE INDEX CARD.**





LESSON  
20



Inglés Paso a Paso con Lucie

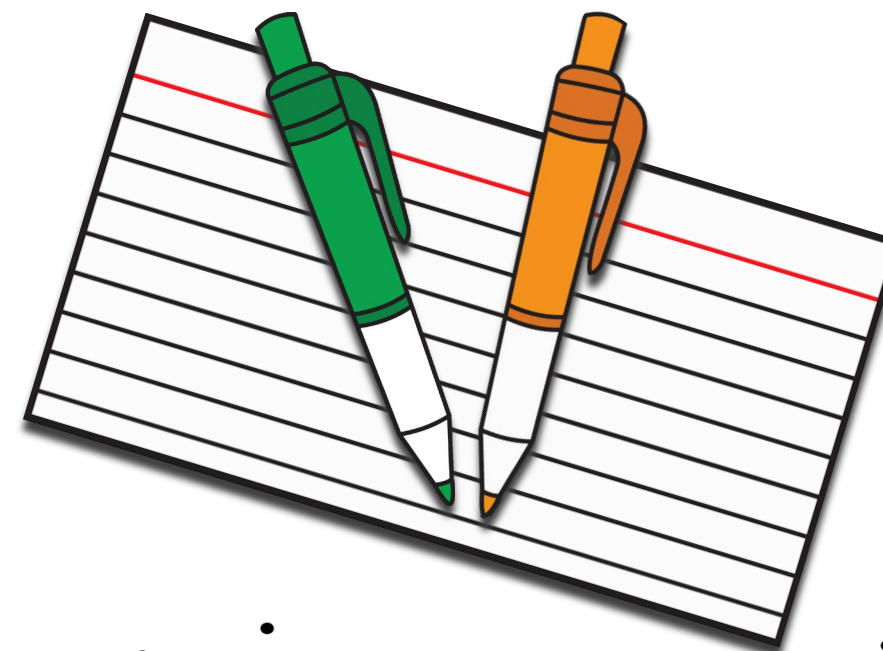
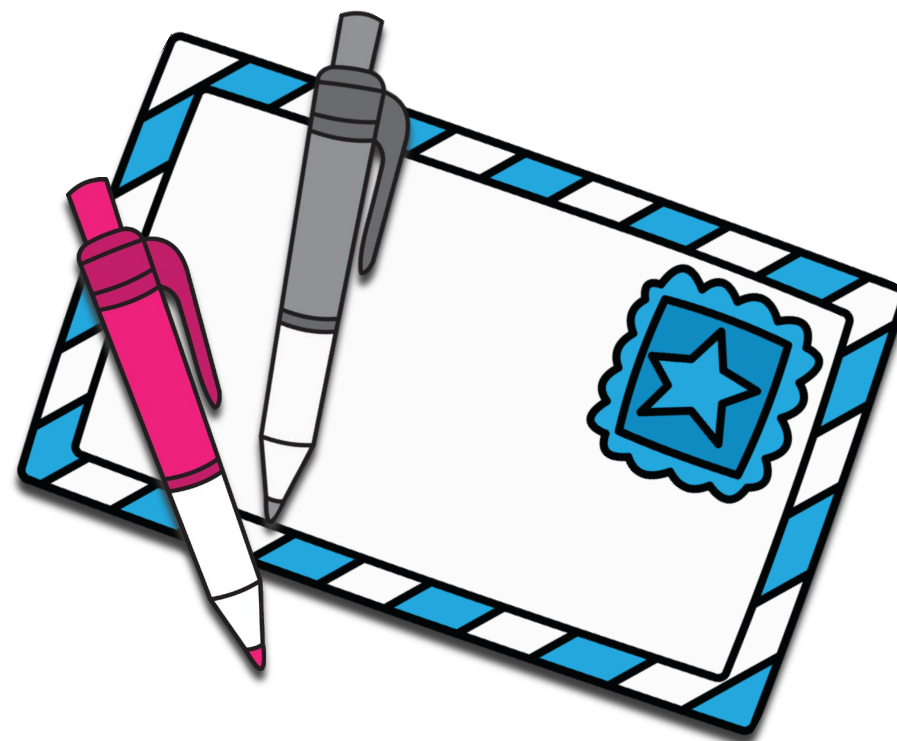
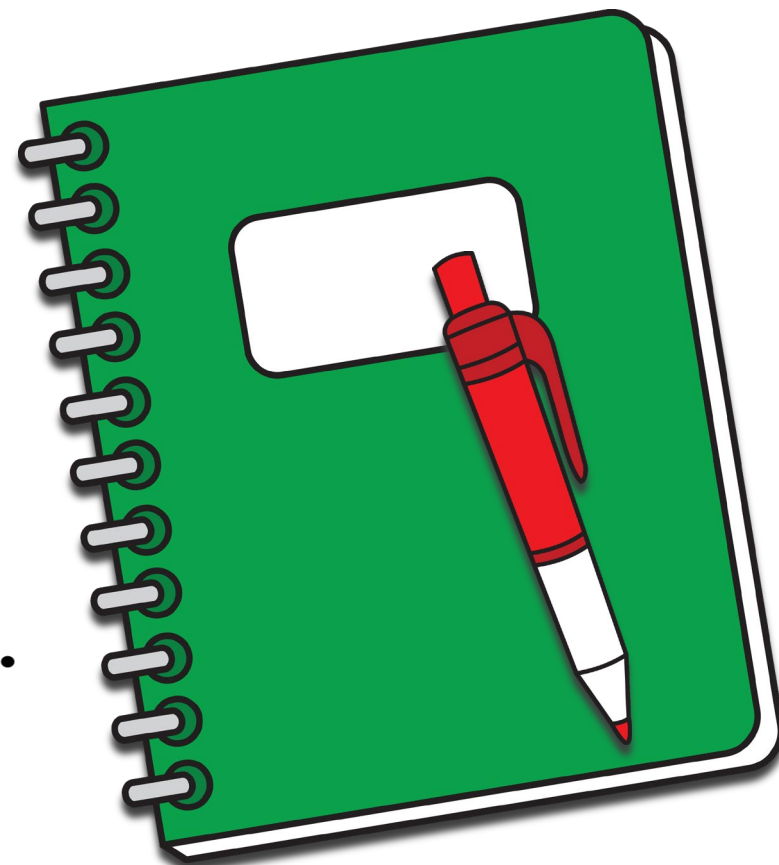
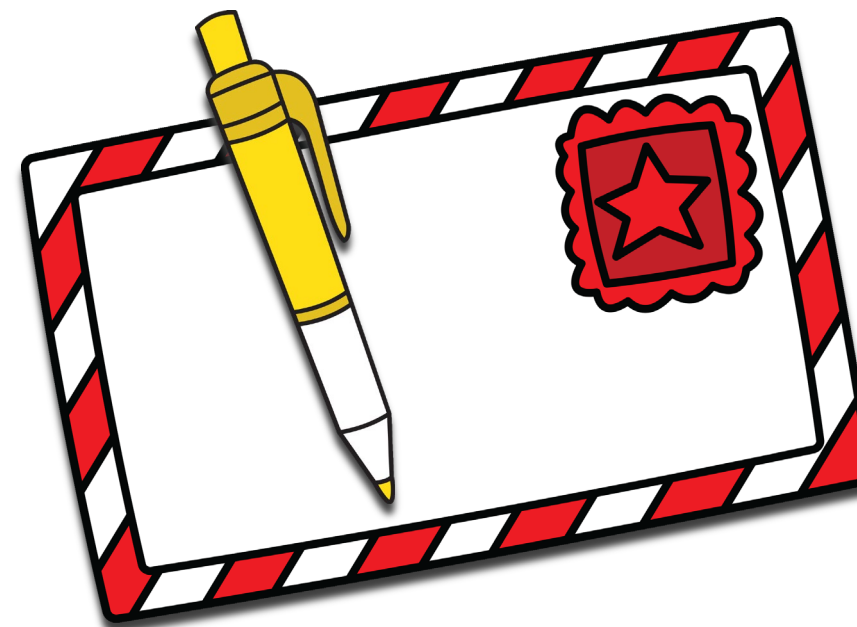
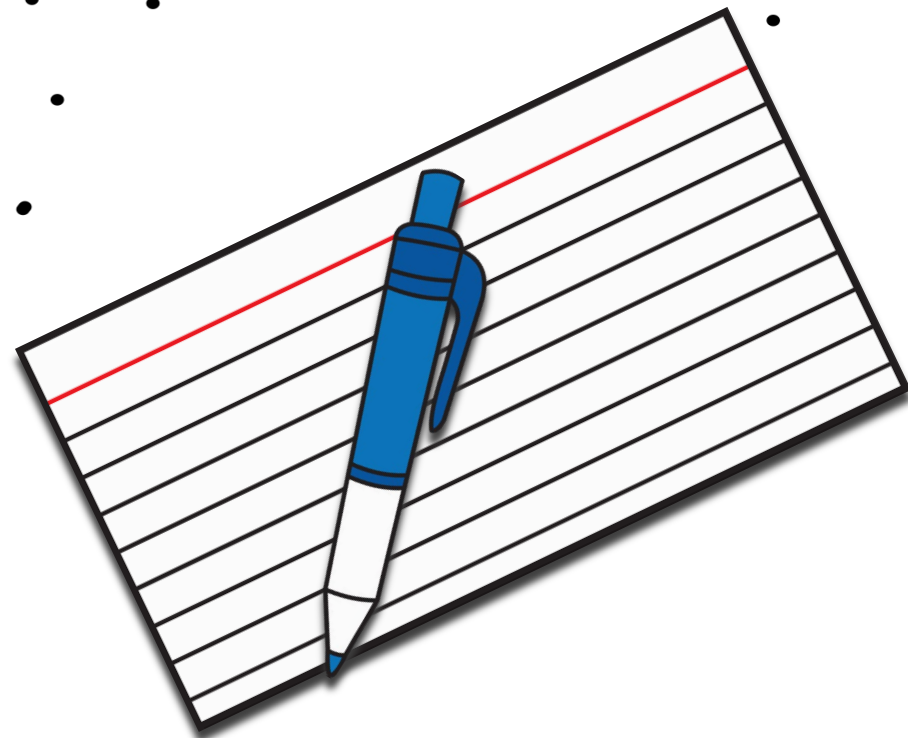

IT &  
THEY





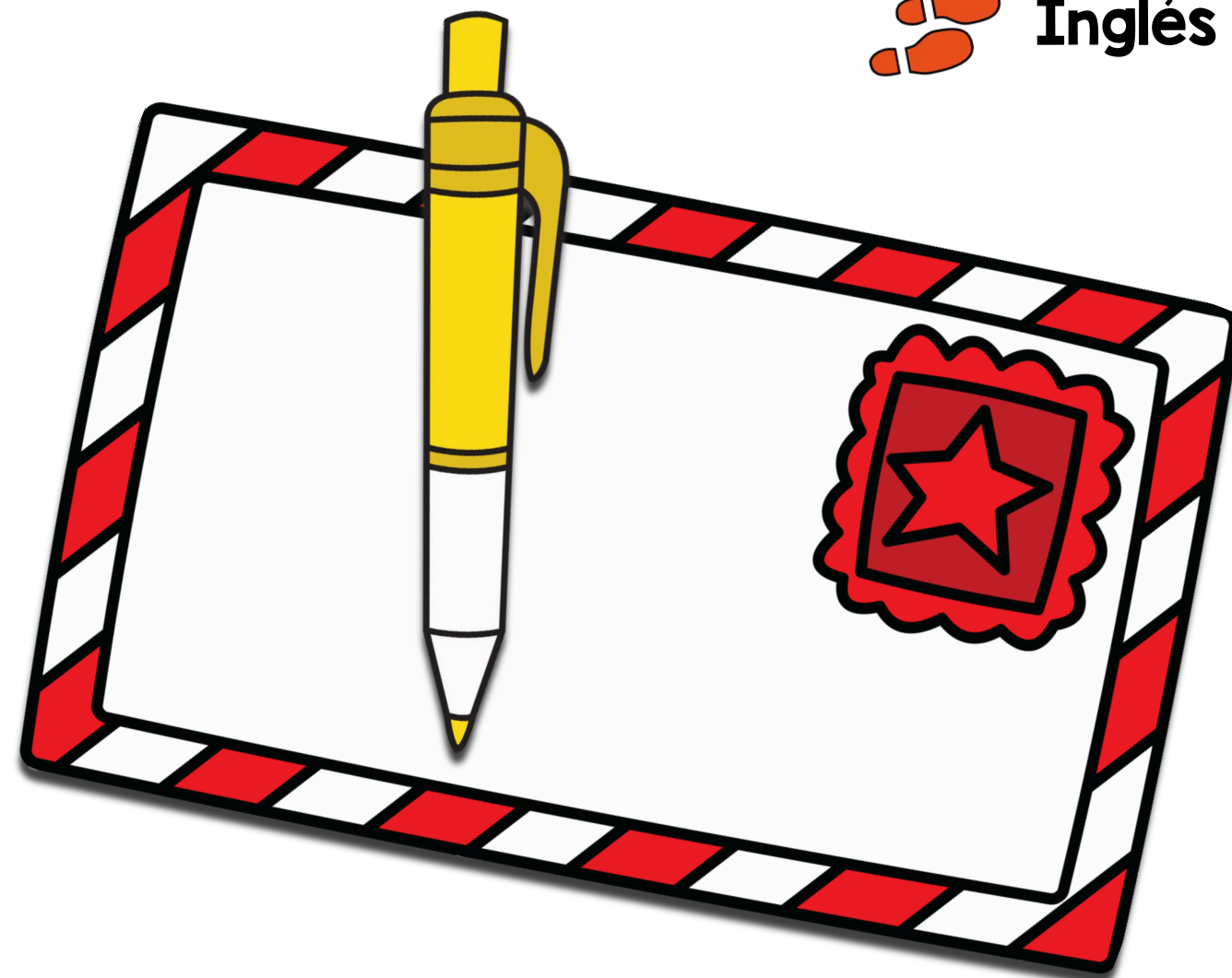

IT &  
THEY

**THE PEN IS  
ON THE ENVELOPE.**





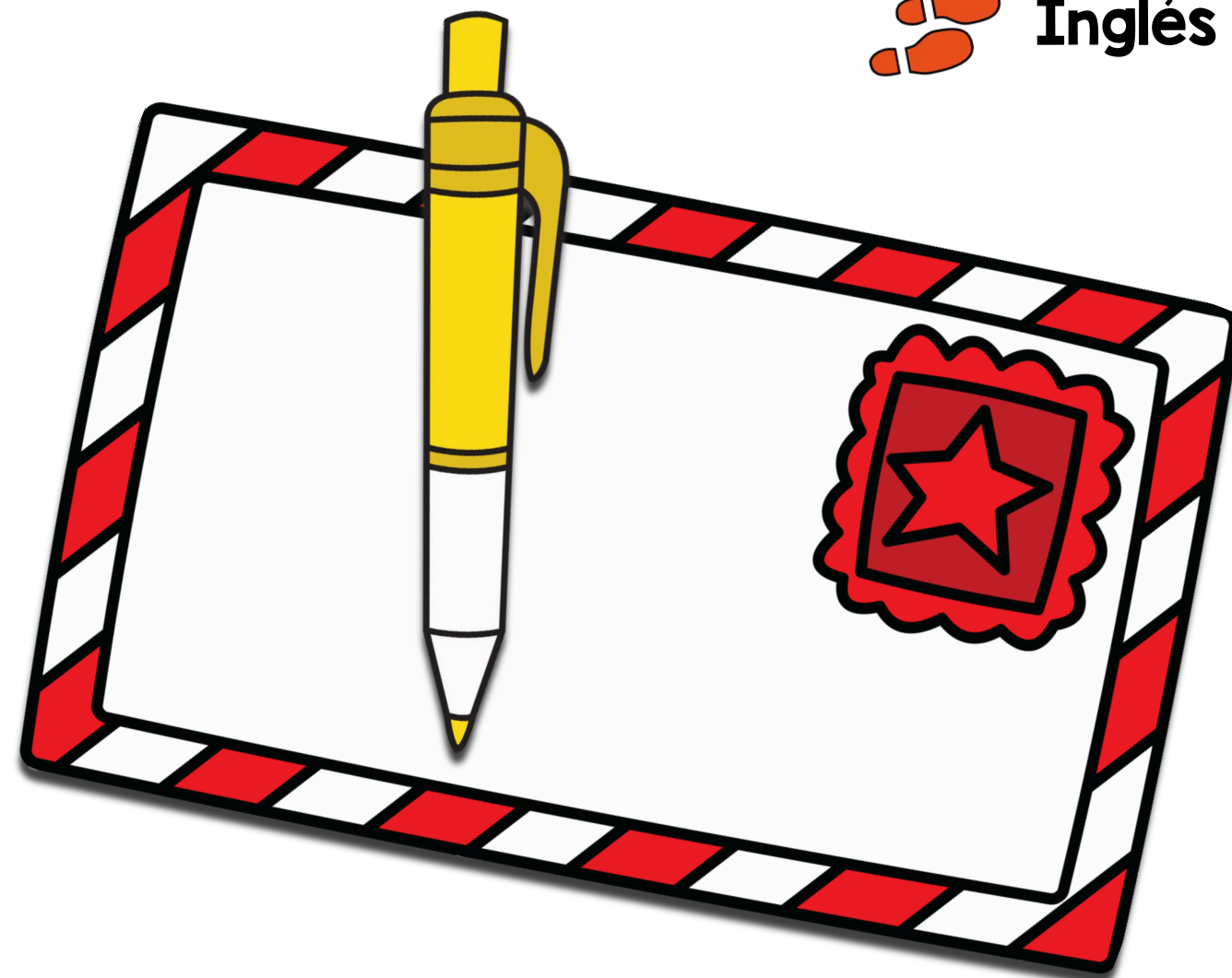

IT &  
THEY

**IT IS**  
**ON THE ENVELOPE.**





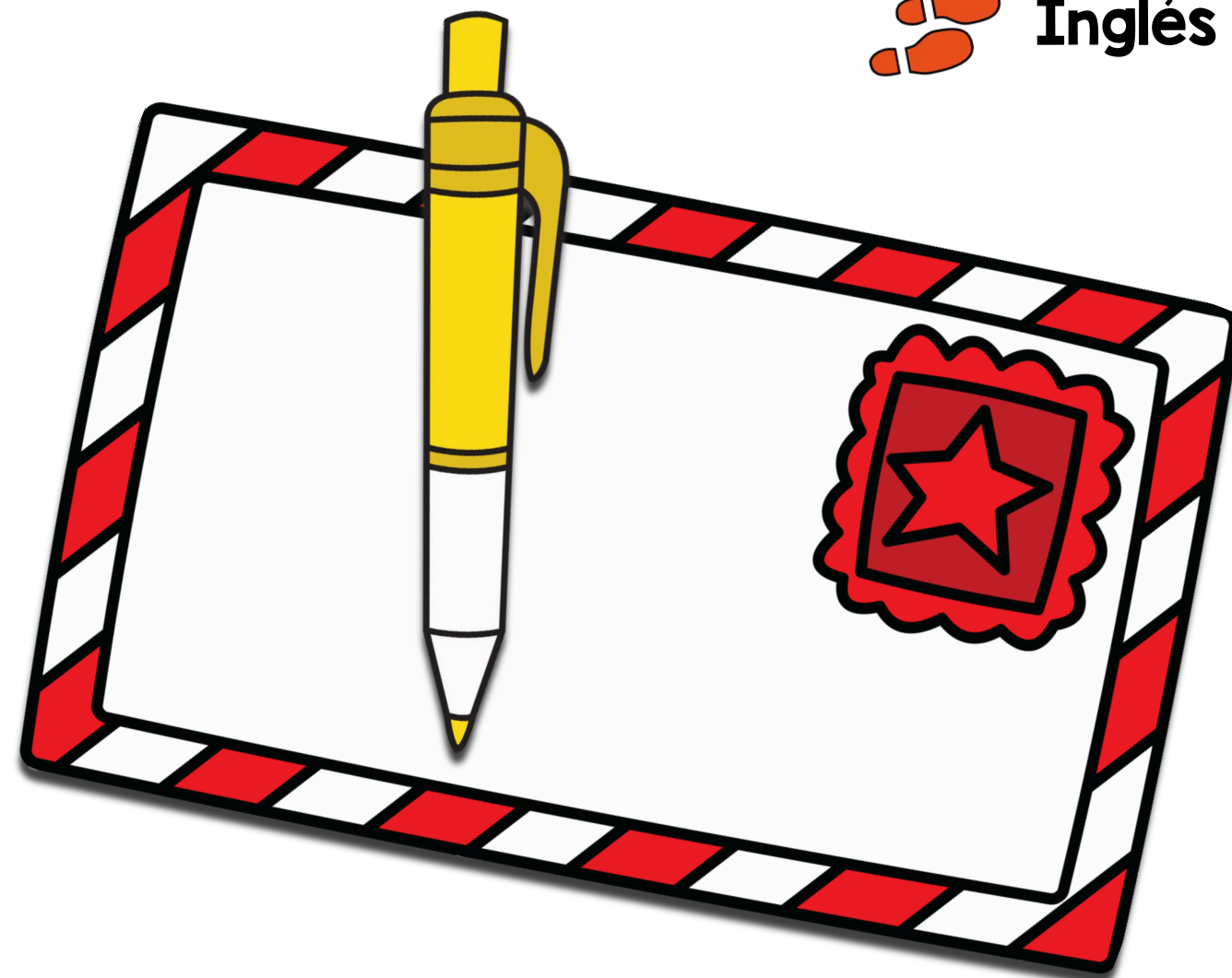

IT &  
THEY

**IT'S**  
**ON THE ENVELOPE.**





LESSON  
20



Inglés Paso a Paso con Lucie

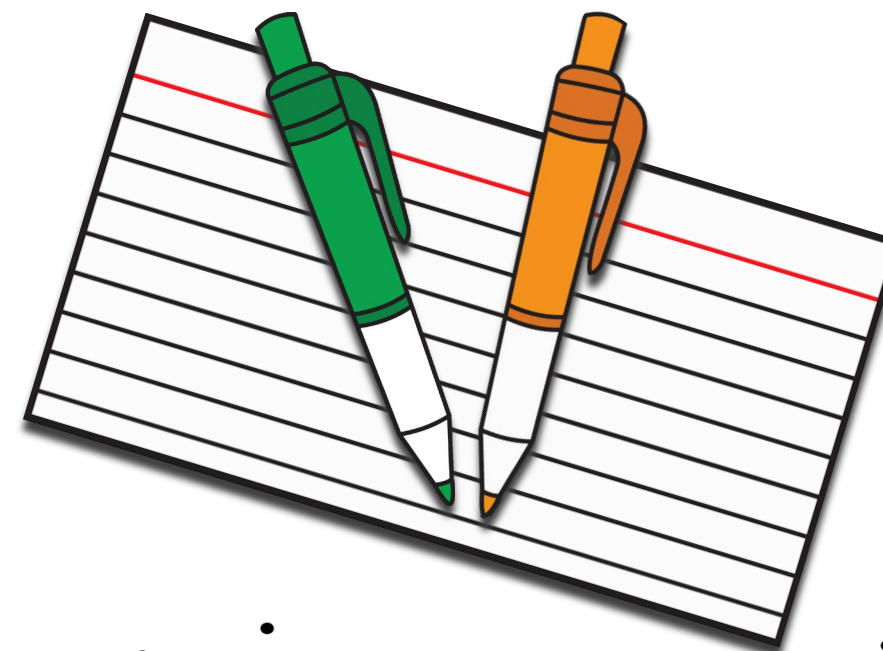
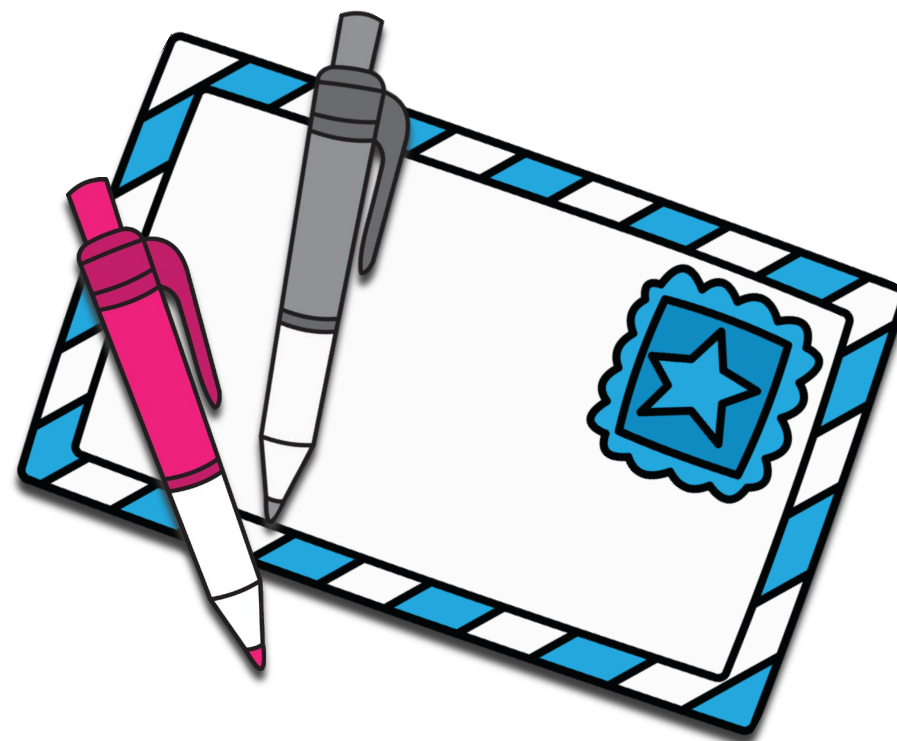
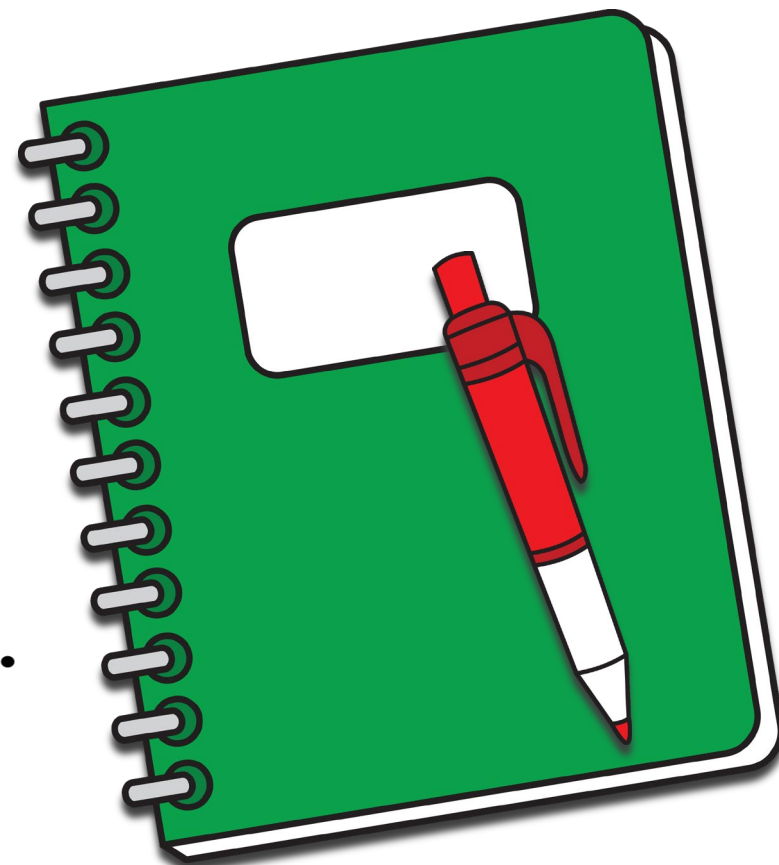
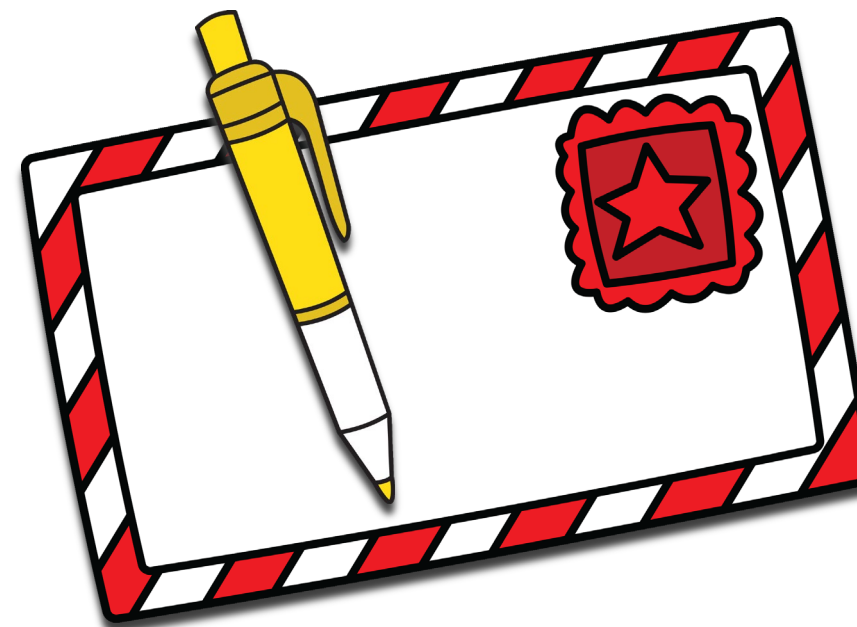
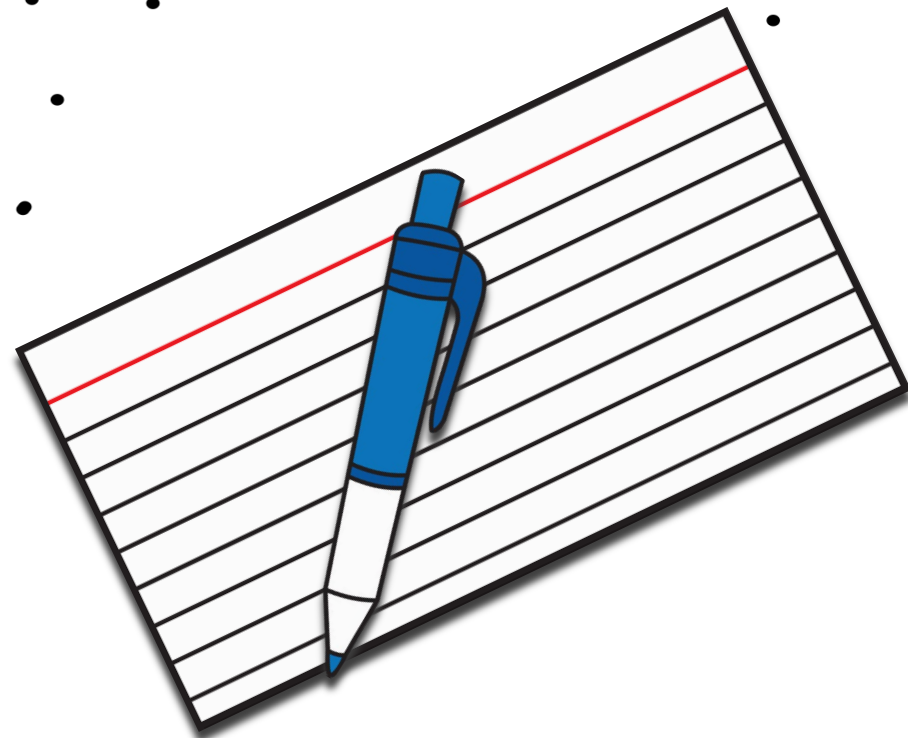

IT &  
THEY







IT &  
THEY

**THE PENS ARE  
ON THE SPIRAL NOTEBOOK.**







IT &  
THEY

**THEY ARE  
ON THE SPIRAL NOTEBOOK.**







IT &  
THEY

**THEY'RE**  
**ON THE SPIRAL NOTEBOOK.**





# GROUP 3

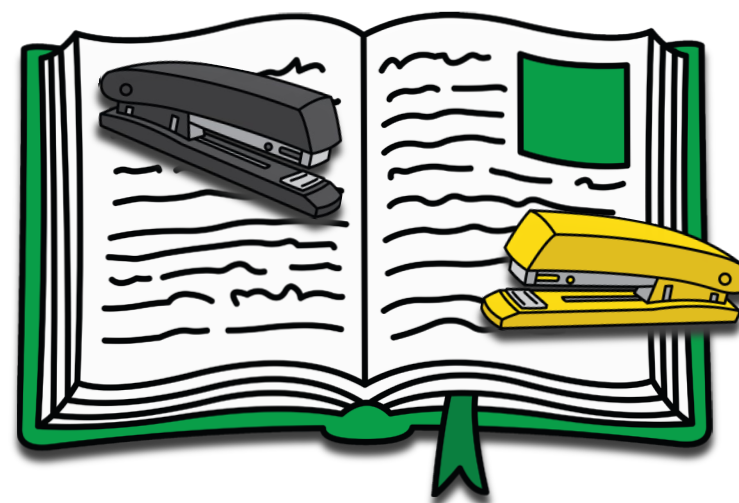
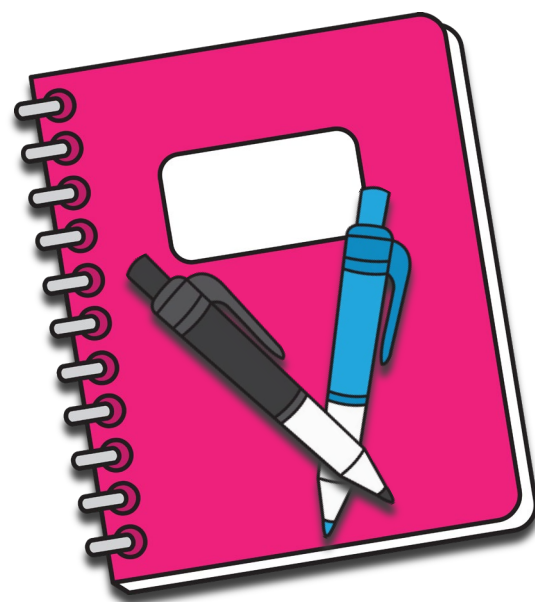
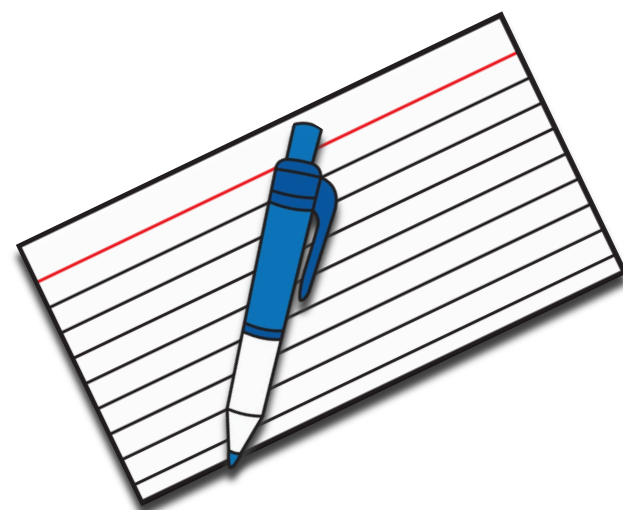
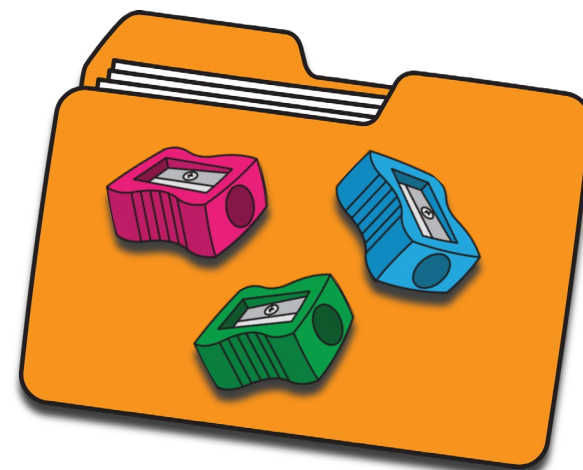
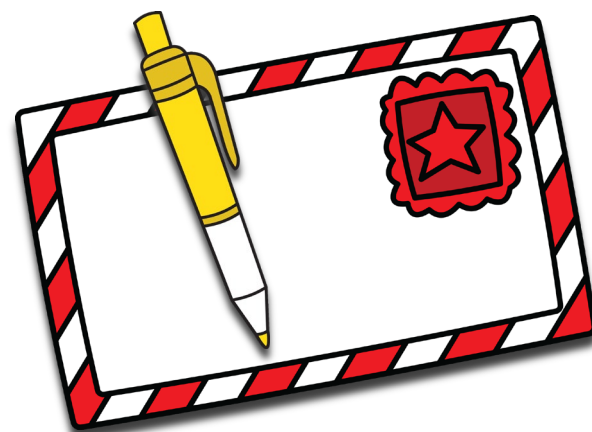

IT &  
THEY





LESSON  
20



Inglés Paso a Paso con Lucie

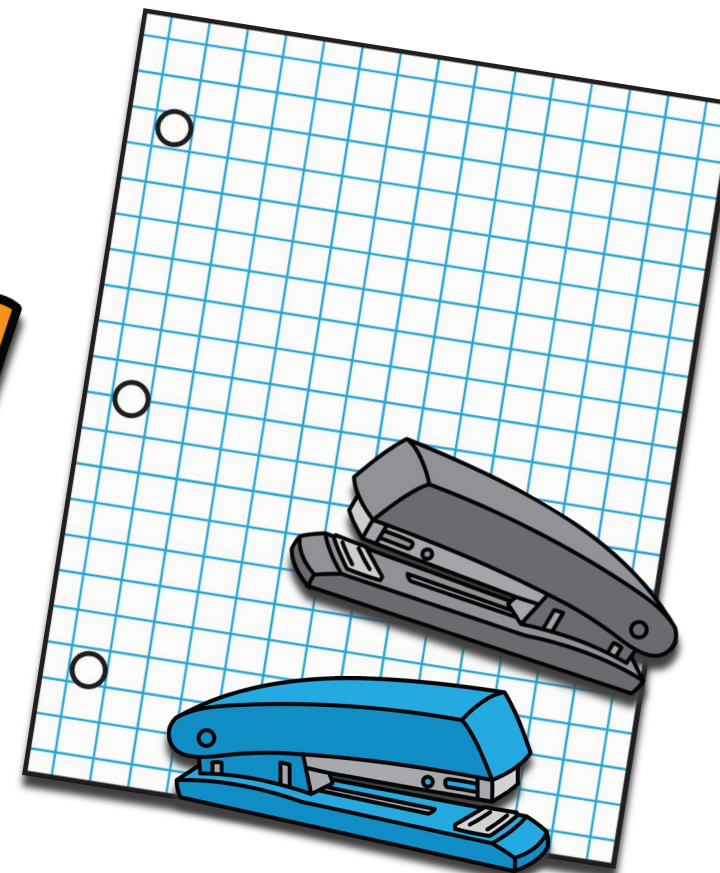
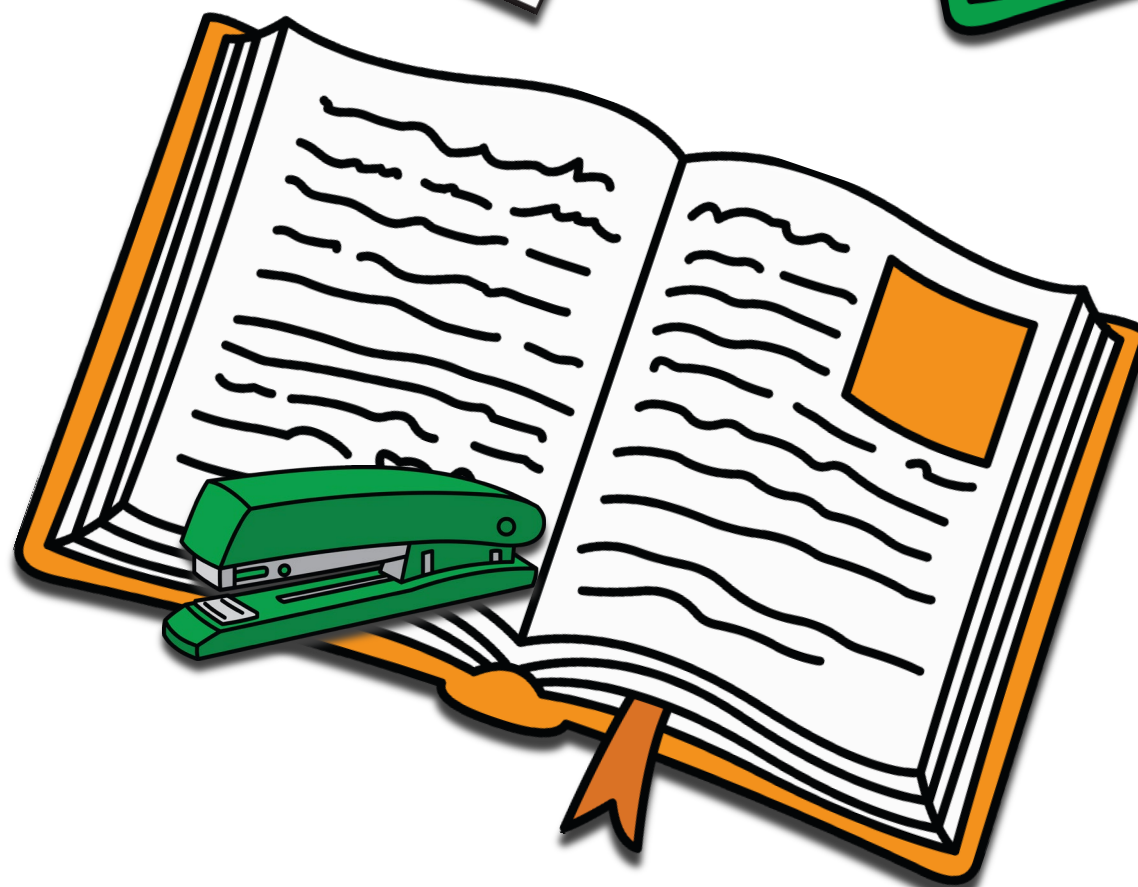
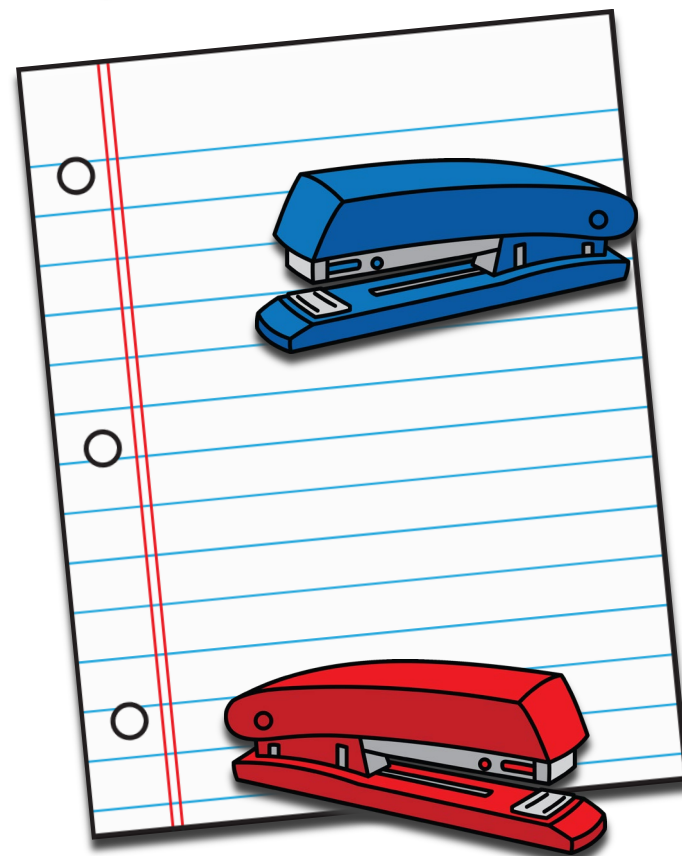
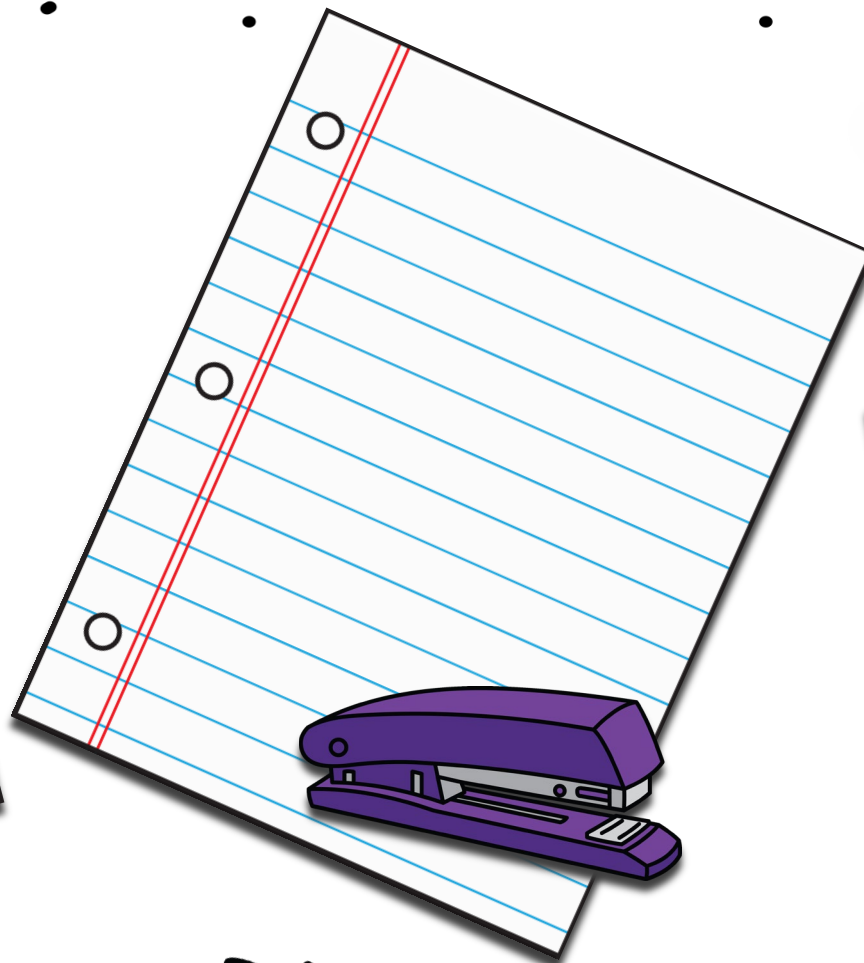
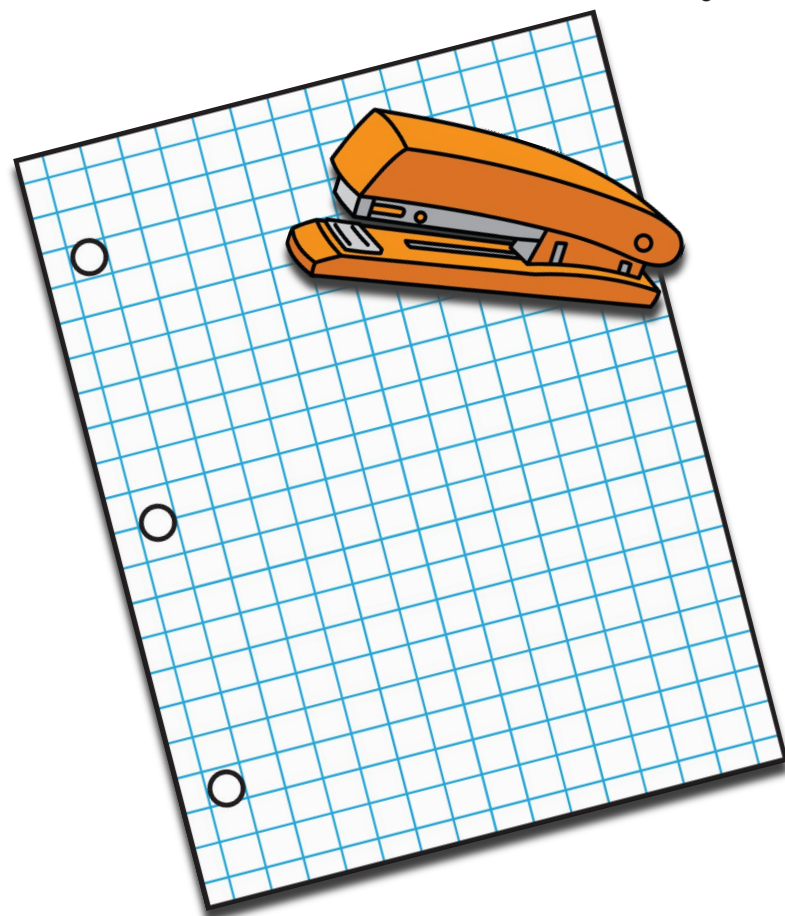

IT &  
THEY





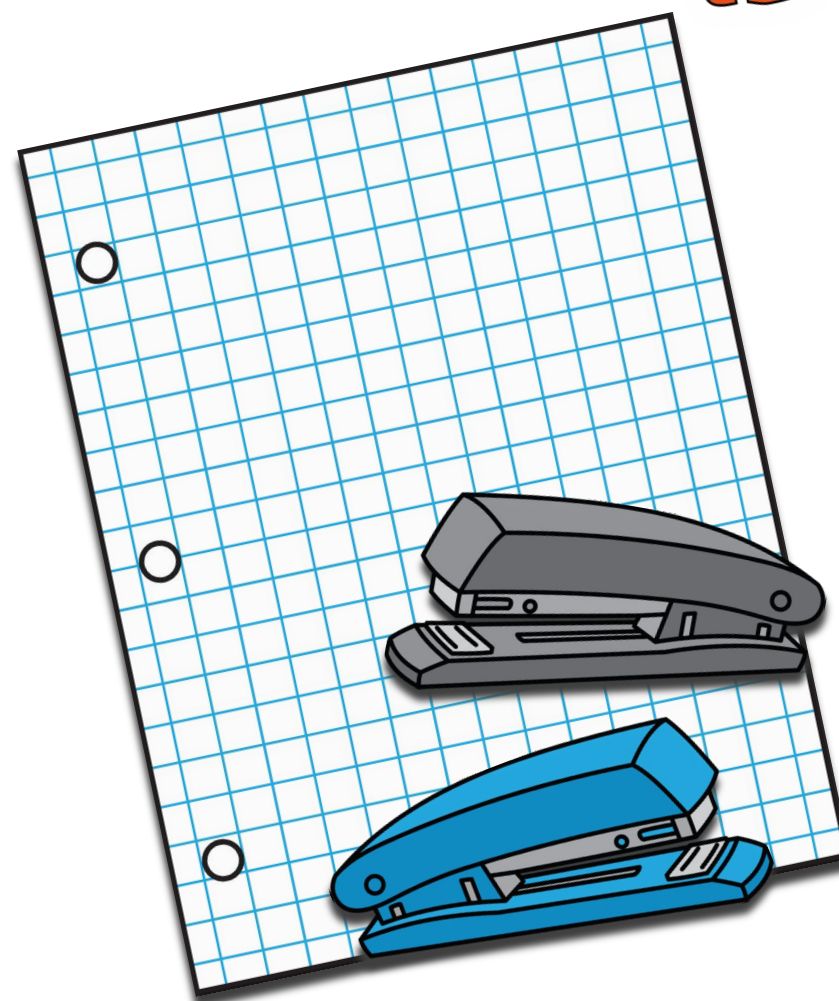

IT &  
THEY

**THE STAPLERS ARE  
ON THE GRAPH PAPER.**





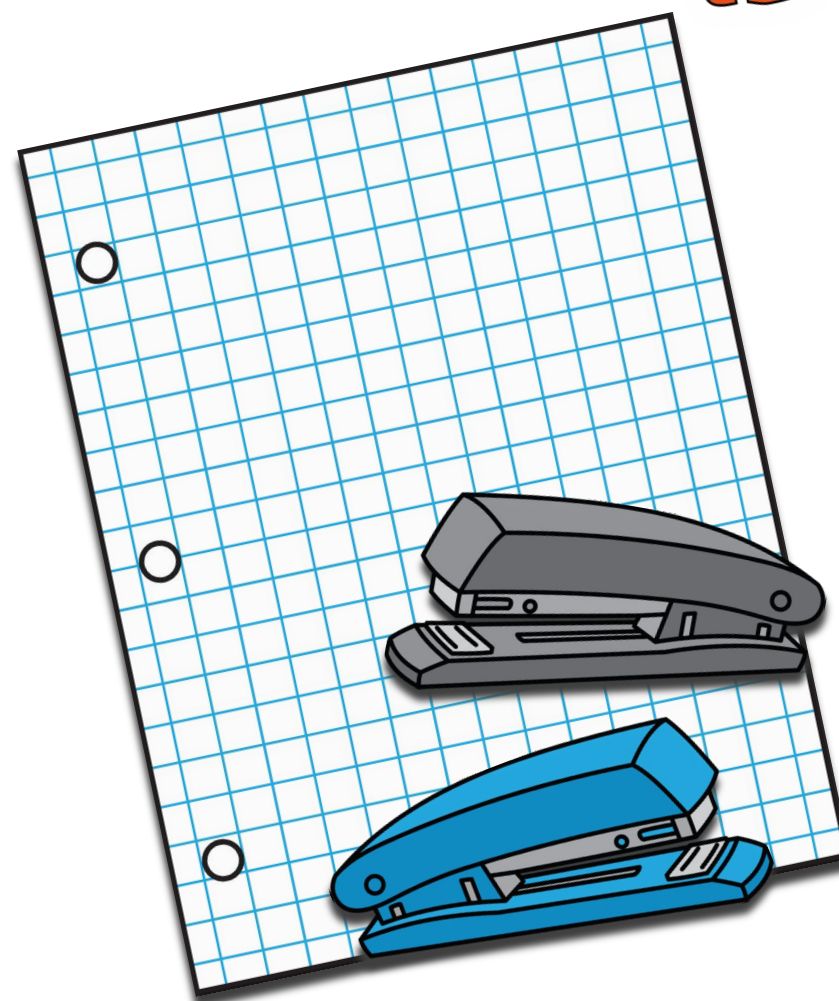

**THEY ARE  
ON THE GRAPH PAPER.**





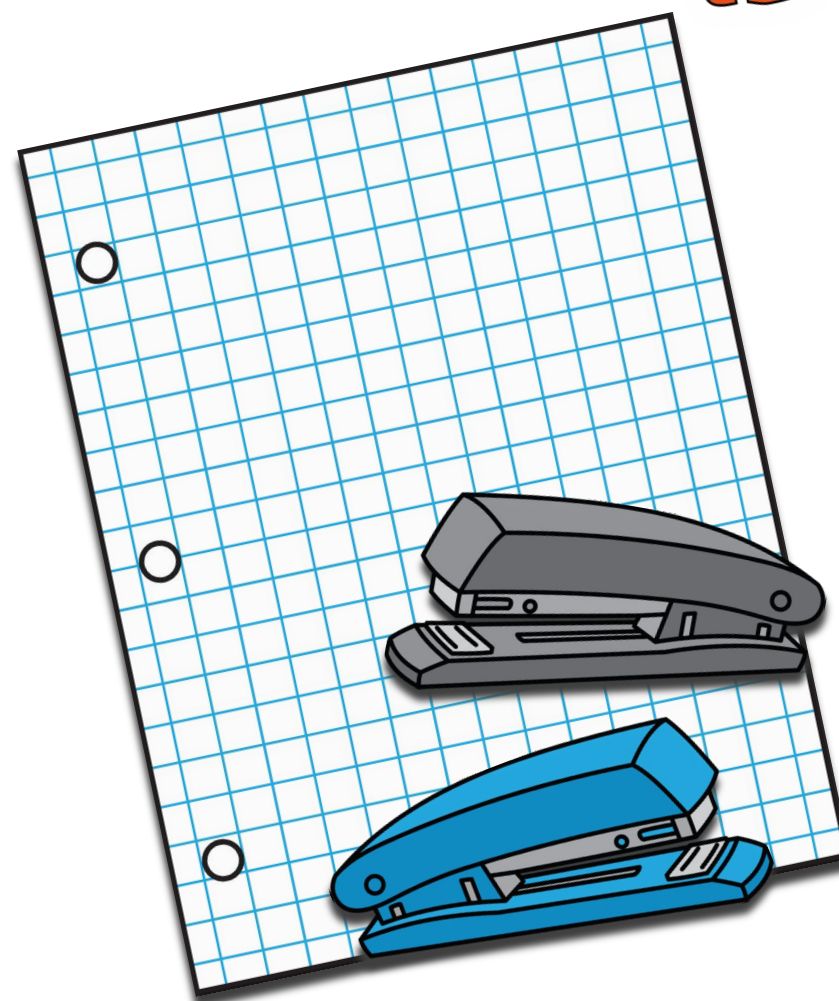

IT &  
THEY

**THEY'RE**  
**ON THE GRAPH PAPER.**





LESSON  
20

 Inglés Paso a Paso con Lucie

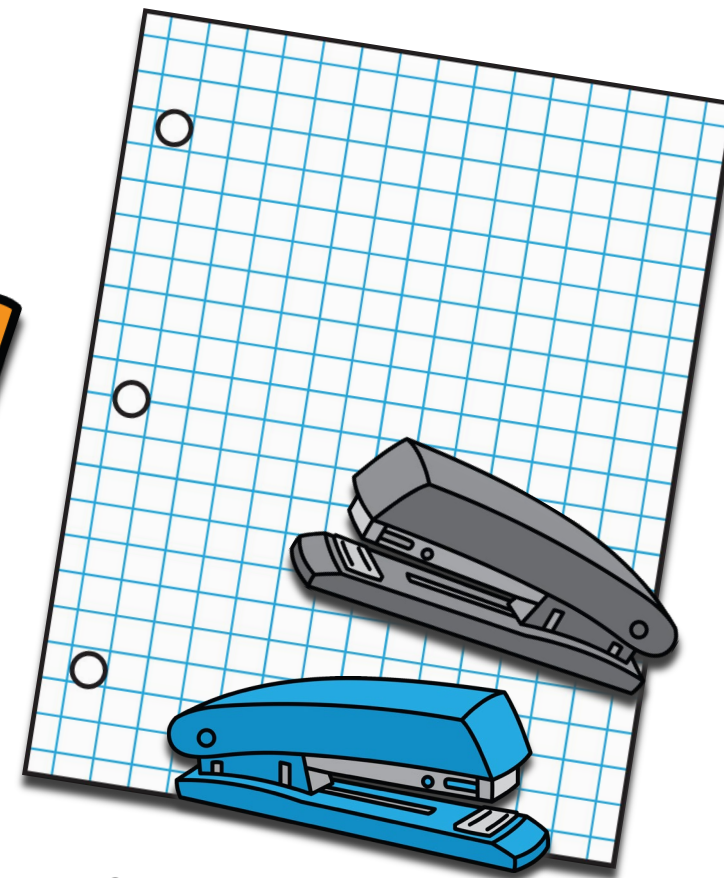
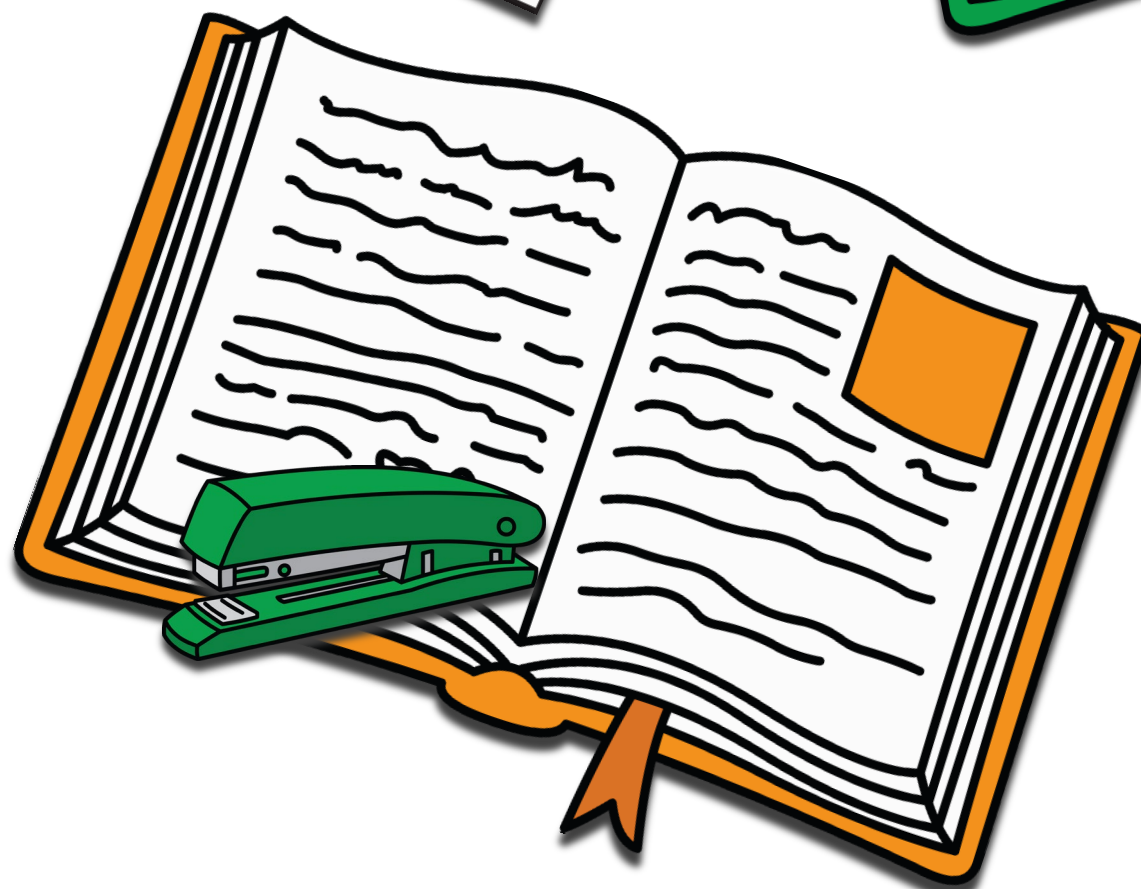
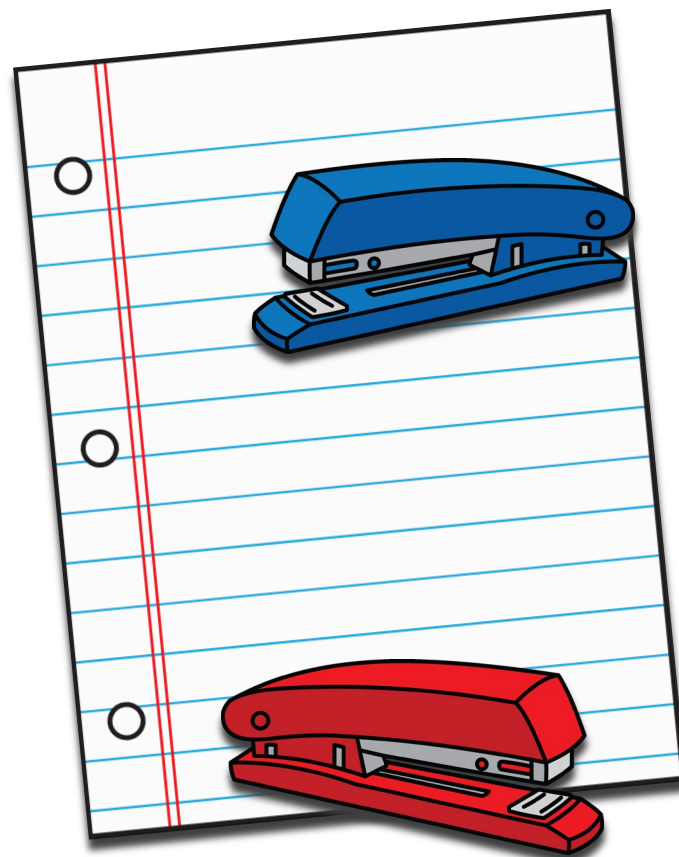
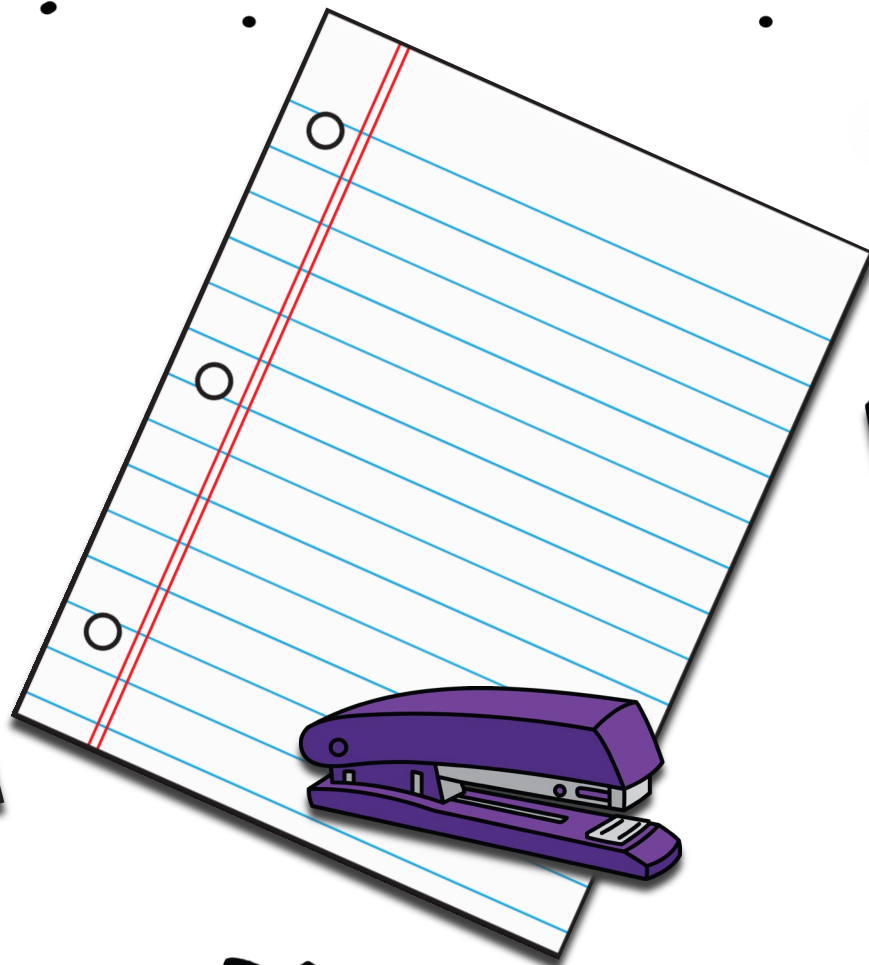
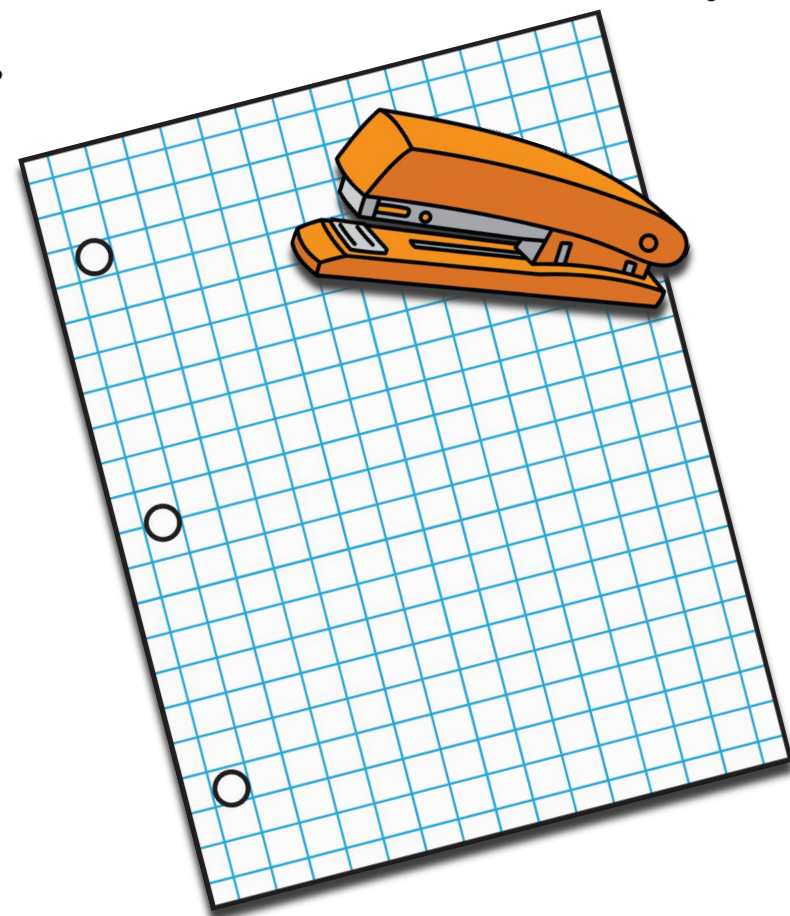

IT &  
THEY







**THE STAPLER IS  
ON THE BOOK.**

IT &  
THEY







**IT IS  
ON THE BOOK.**







**IT'S**  
**ON THE BOOK.**





LESSON  
20

 Inglés Paso a Paso con Lucie

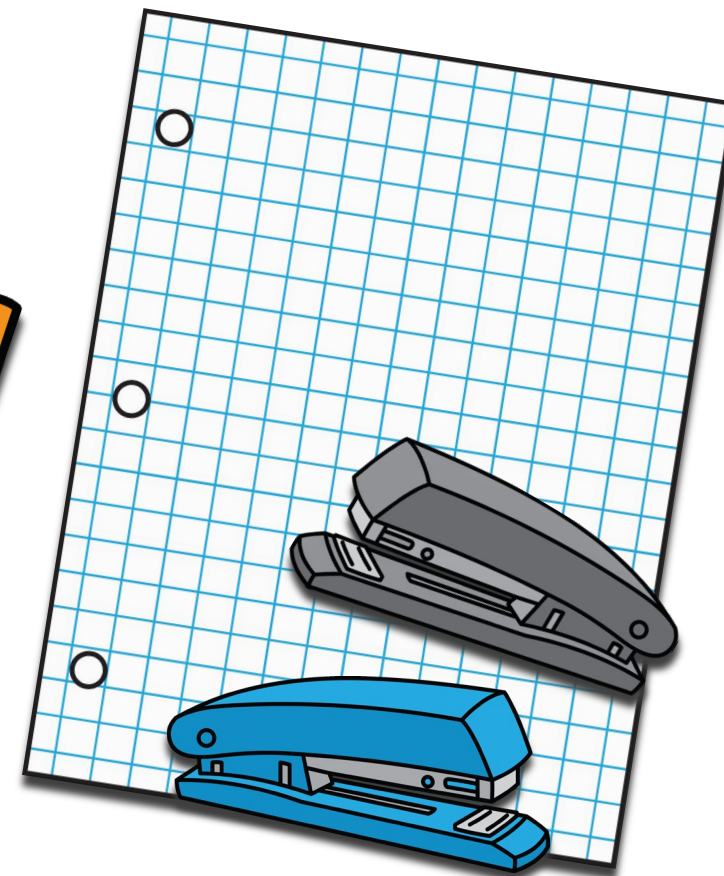
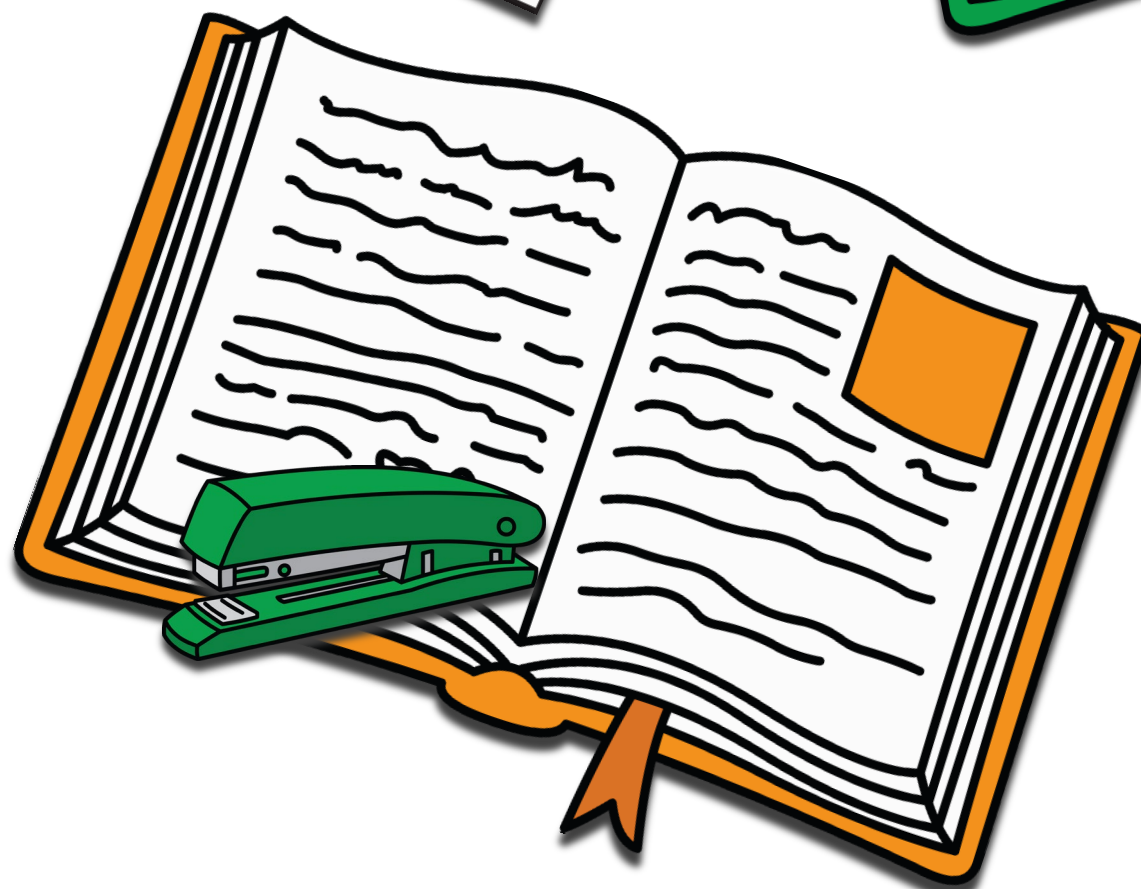
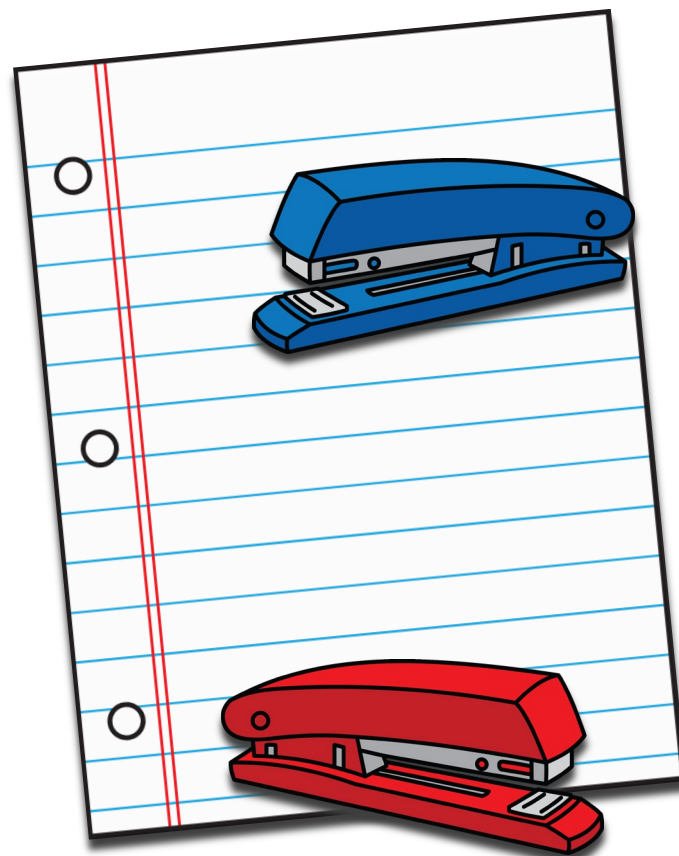
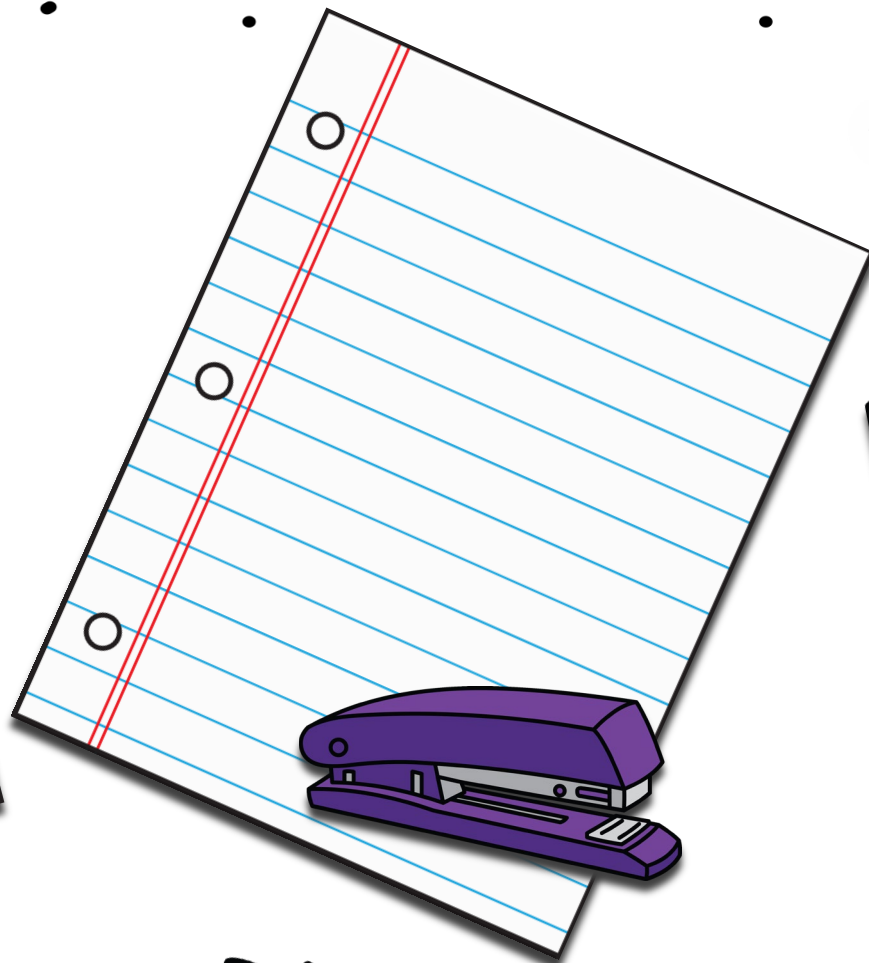
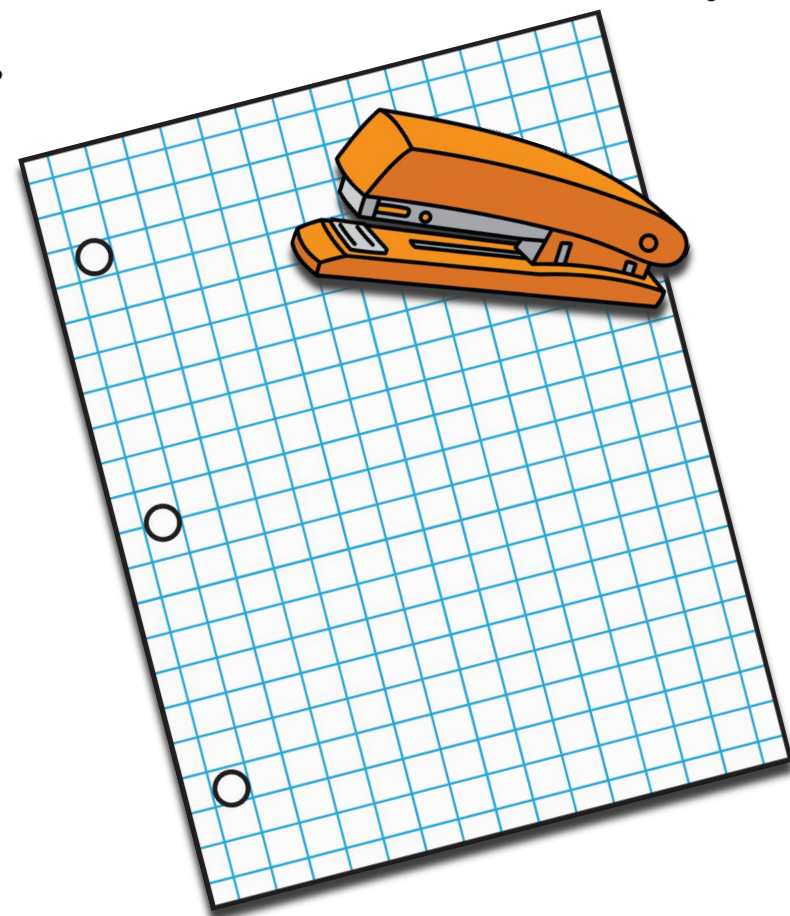

IT &  
THEY





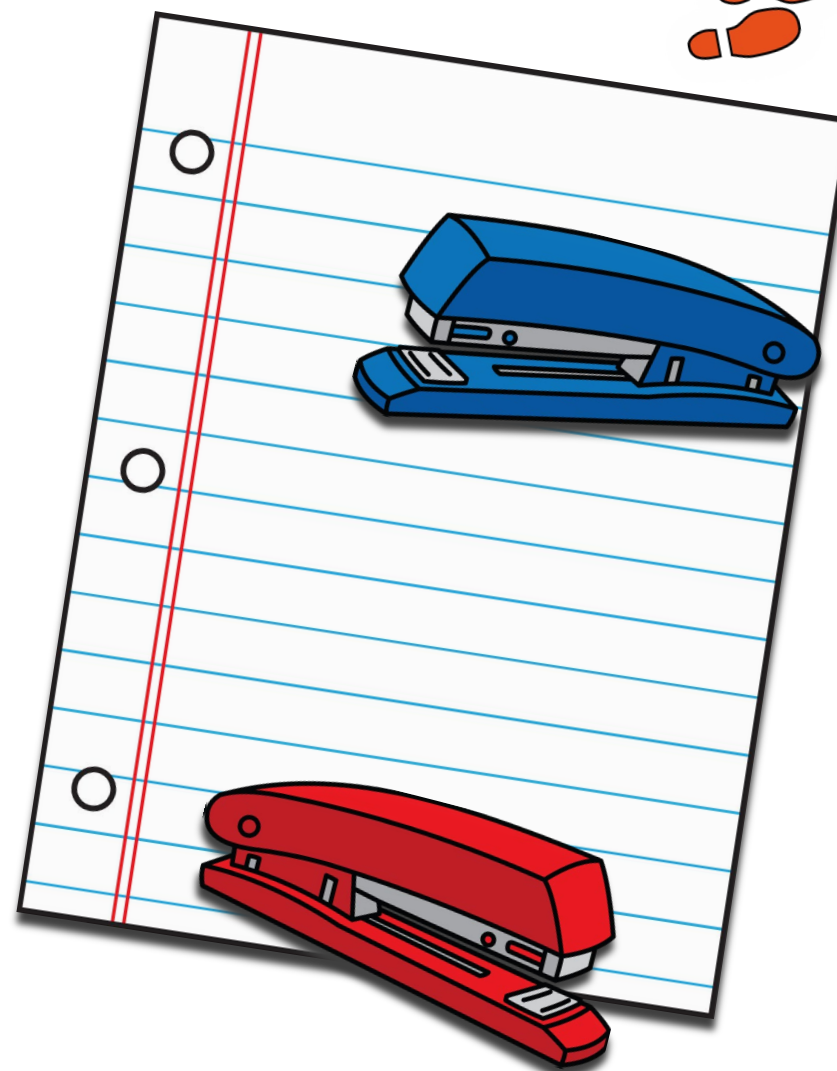

**THE STAPLERS ARE  
ON THE LINED PAPER.**





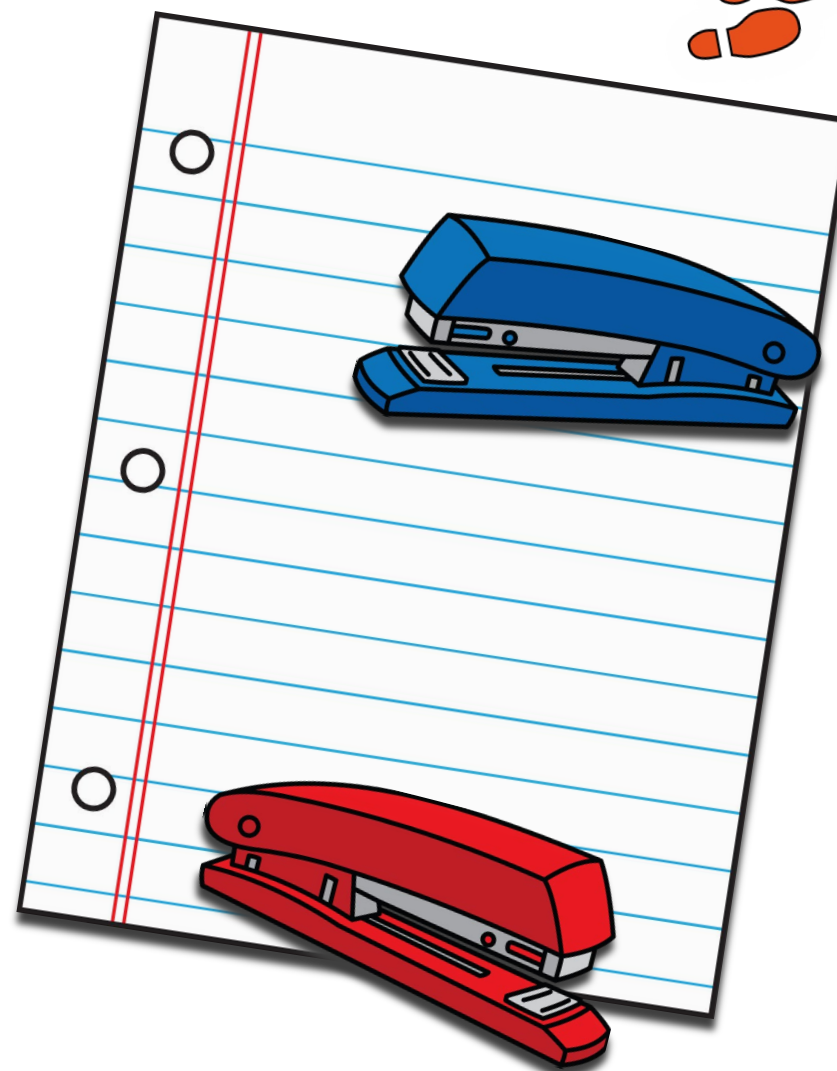

**THEY ARE**  
**ON THE LINED PAPER.**



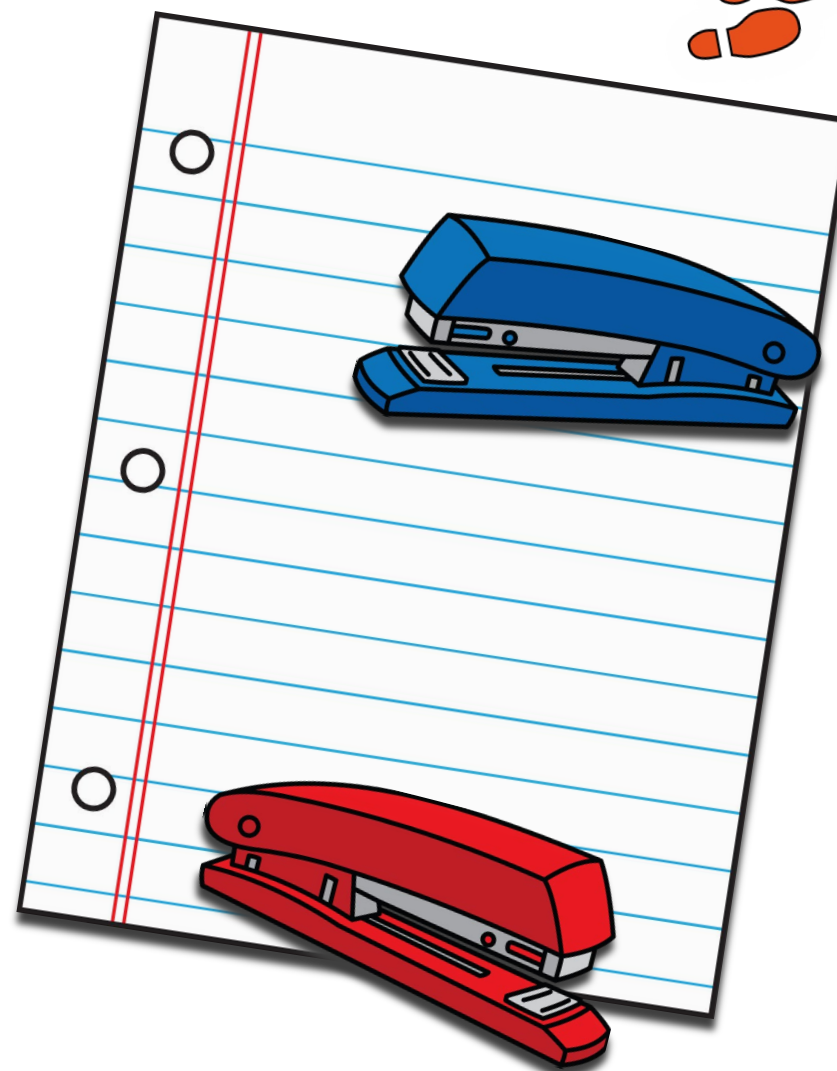

**THEY'RE**  
**ON THE LINED PAPER.**



# GROUP 4

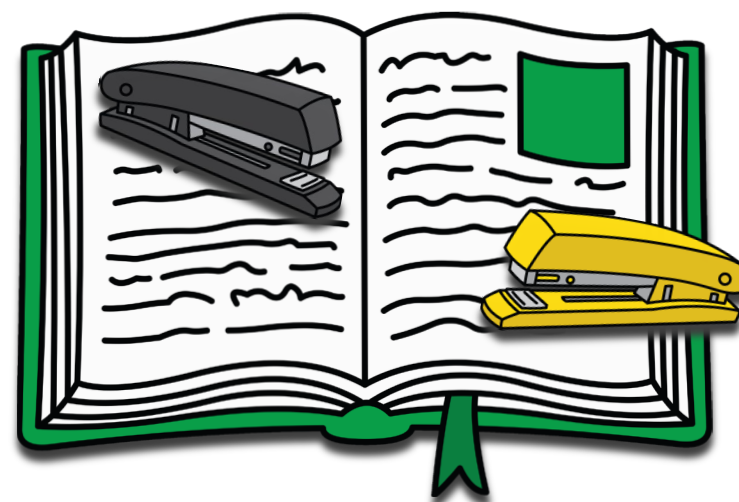
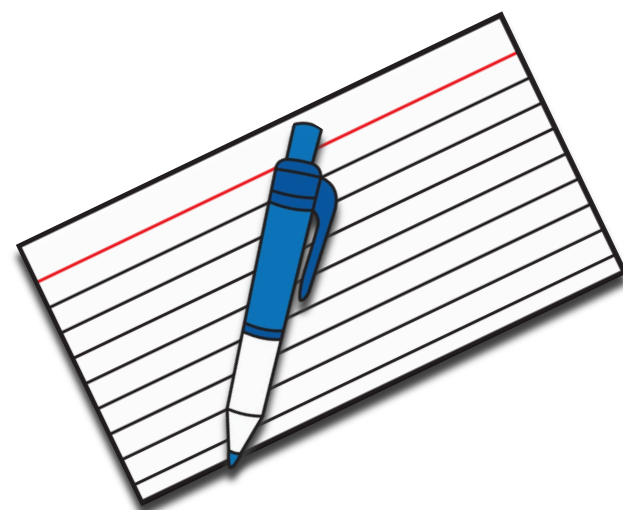
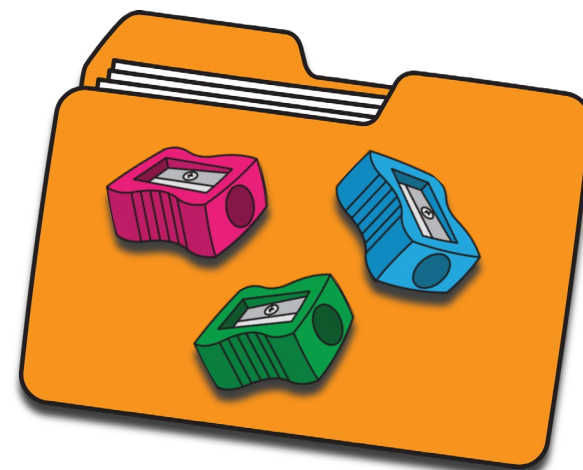
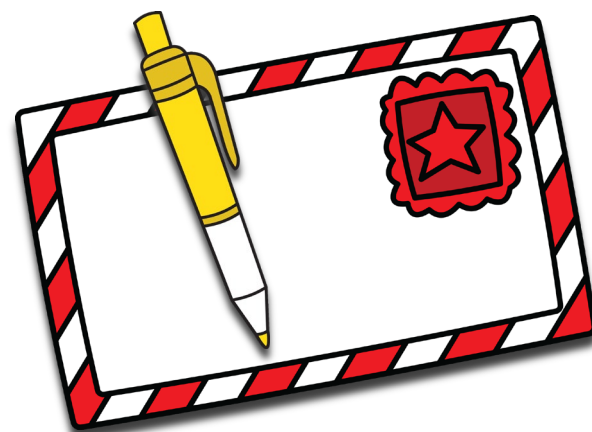

IT &  
THEY





LESSON  
20



Inglés Paso a Paso con Lucie



IT &  
THEY







IT &  
THEY

**THE BRUSHES ARE  
ON THE STICKY NOTES.**







IT &  
THEY

**THEY ARE  
ON THE STICKY NOTES.**







IT &  
THEY



**THEY'RE**  
**ON THE STICKY NOTES.**



LESSON  
20



Inglés Paso a Paso con Lucie



IT &  
THEY





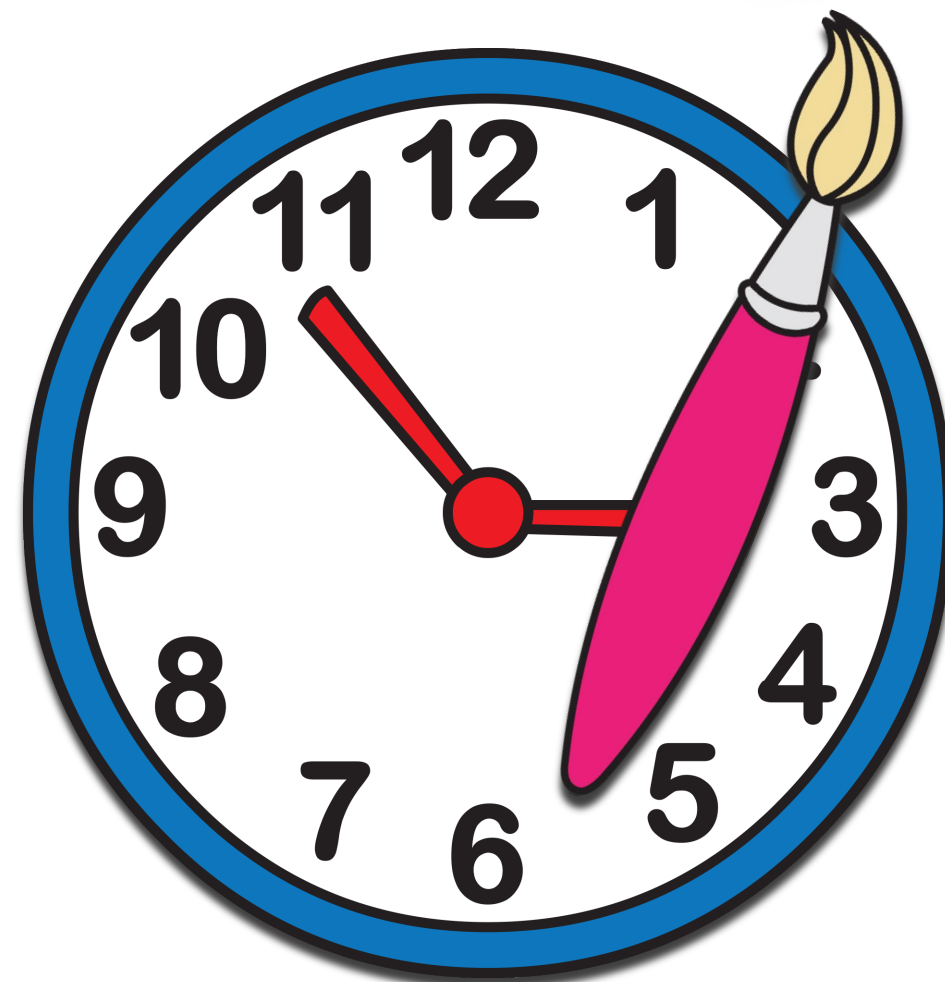

**THE BRUSH IS  
ON THE CLOCK.**

IT &  
THEY







**IT IS**  
**ON THE CLOCK.**

**IT &  
THEY**







**IT'S**

**ON THE CLOCK.**

**IT &  
THEY**





LESSON  
20



Inglés Paso a Paso con Lucie



IT &  
THEY







**THE BRUSHES ARE  
ON THE MARKERS.**

IT &  
THEY

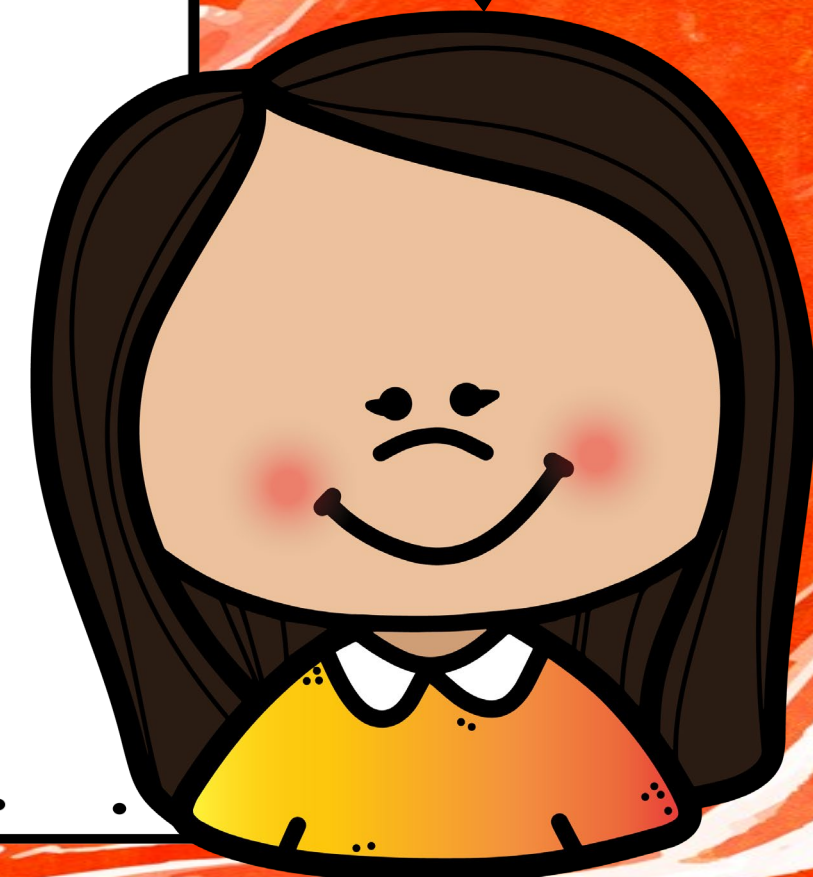





**THEY ARE  
ON THE MARKERS.**

IT &  
THEY







**THEY'RE**

**ON THE MARKERS.**

IT &  
THEY





**DERECHOS DE USO:**

Queda prohibido vender o hacer uso comercial de cualquier parte del material y videos encontrados en el canal de YouTube y sitio web de: Inglés Paso a Paso con Lucie / Cursos de Inglés ATS.

No se puede alterar ninguna parte de este material para venderlo o usarlo como parte de un curso en linea o presencial, editarlo, cargarlo a redes sociales, o hacer cualquier otro uso que no esté autorizado por escrito.

IT &  
THEY

GRAPHIC CREDITS



Bubbly Borders and more!

